

DYNAMIC TRIM CONTROL SYSTEM

SERIES E PRO

PRODUCT SPECIFICATION



ZIPWAKE

TRIM CONTROL MADE EASY

DISCLAIMER

ALL PRODUCT SPECIFICATIONS AND DATA ARE SUBJECT TO CHANGE WITHOUT NOTICE TO IMPROVE RELIABILITY, FUNCTION OR DESIGN OR OTHERWISE.

Zipwake, its affiliates, agents, and employees, and all persons acting on its or their behalf (collectively, "Zipwake"), disclaim any and all liability for any errors, inaccuracies or incompleteness contained in any datasheet or in any other disclosure relating to any product.

zipwake.com

PRODUCT SPECIFICATION

DYNAMIC TRIM CONTROL SYSTEM SERIES E PRO

Part number: 1010199

Release: R1F, March 2026

Language: English

Copyright © 2026 Zipwake AB, Sweden. All rights reserved.

TABLE OF CONTENTS

1	INTRODUCTION	5
1.1	MOTION CONTROL FEATURES	
1.2	CONFIGURABLE LIFT FORCE ALLOCATION	
1.3	PRODUCTS AND PARTS OVERVIEW	
2	KIT BOXES	10
2.1	KIT BOX CONTENTS	
2.2	SPECIFICATIONS	
2.3	ORDERING DATA	
3	CONTROL PANEL	12
3.1	FEATURES	
3.2	SPECIFICATIONS	
3.3	INTERFACES	
3.4	DIMENSIONS	
3.5	ORDERING DATA	
4	INTEGRATOR MODULE	14
4.1	FEATURES	
4.2	SPECIFICATIONS	
4.3	INTERFACES	
4.4	DIMENSIONS	
4.5	ORDERING DATA	
5	MINI CONTROLLER	16
5.1	FEATURES	
5.2	INTERFACES	
5.3	SPECIFICATIONS	
5.4	DIMENSIONS	
5.5	ORDERING DATA	
6	INTERCEPTORS	18
6.1	FEATURES	
6.2	SPECIFICATIONS	
6.3	DIMENSIONS	
6.4	ORDERING DATA	
7	DISTRIBUTION UNITS	26
7.1	SPECIFICATIONS	
7.2	CONNECTORS	
7.3	DIMENSIONS	
7.4	ORDERING DATA	
8	CABLES	28
8.1	SPECIFICATIONS	
8.2	ORDERING DATA	
9	CONTROL PANEL ALU FRAME	29
9.1	SPECIFICATIONS	
9.2	ORDERING DATA	
10	CONTROL PANEL COVER	29
10.1	SPECIFICATIONS	
10.2	ORDERING DATA	
11	CONTROL PANEL GIMBAL BRACKET	30
11.1	SPECIFICATIONS	
11.2	DIMENSIONS	
11.3	ORDERING DATA	
12	CABLE COVER EXTENSION KIT	31
12.1	SPECIFICATIONS	
12.2	DIMENSIONS	
12.3	ORDERING DATA	
13	SERVO UNIT	32
13.1	SPECIFICATIONS	
13.2	ORDERING DATA	
14	INTERCEPTOR FRONTS	33
14.1	SPECIFICATIONS	
14.2	DIMENSIONS	
14.3	ORDERING DATA	
15	EXTERNAL GPS ANTENNA	34
15.1	APPLICATION	
15.2	SPECIFICATIONS	
15.3	PIN OUT	
15.4	DIMENSIONS	
15.5	ORDERING DATA	
16	UPGRADE KIT PRO	35
16.1	ORDERING DATA	
17	WIRING DIAGRAM	36



1 INTRODUCTION

The Dynamic Trim Control System Series E Pro is an evolved version of the successful Series E that now incorporates pro active motion control, voltage boost and twelve ultra-fast, large durable interceptors. The system is perfectly engineered to suit planing or semi-planing boats and can be configured for monohull or multihull boats, up to 30 m (100 ft). Unique 3D controls provide the helmsman with unmatched, user-friendly, intuitive and precise control of running trim, heel or heading. The system is fully automatic and significantly enhances the boat's performance, fuel economy, comfort and safety.

KEY FEATURES

COMFORT AND SAFETY

Dynamically eliminates uncomfortable and dangerous boat pitch and roll.

PERFORMANCE AND FUEL ECONOMY

Automatically minimizes wave resistance and saves fuel.

INTUITIVE AND PRECISE CONTROL

Innovative 3D controls provide unmatched control of running trim, heel or heading.

DURABLE AND ULTRA-FAST

Patented series of large, durable, ultra-fast interceptors provide supreme lift force characteristics.

COMPLETE AND COMPETITIVE

All-inclusive standardized modular design provides built-in quality, simple installation and easy expansion, while making the system affordable.

INTEGRATION

The integrator module enables integration with complete system control on compatible multifunction displays (MFDs), making flexible installations and clean dashboard solutions possible. It is also possible to monitor system data on a wide range of plotters via the system's NMEA 2000® interface. The integrator module is compatible with all Zipwake system components.

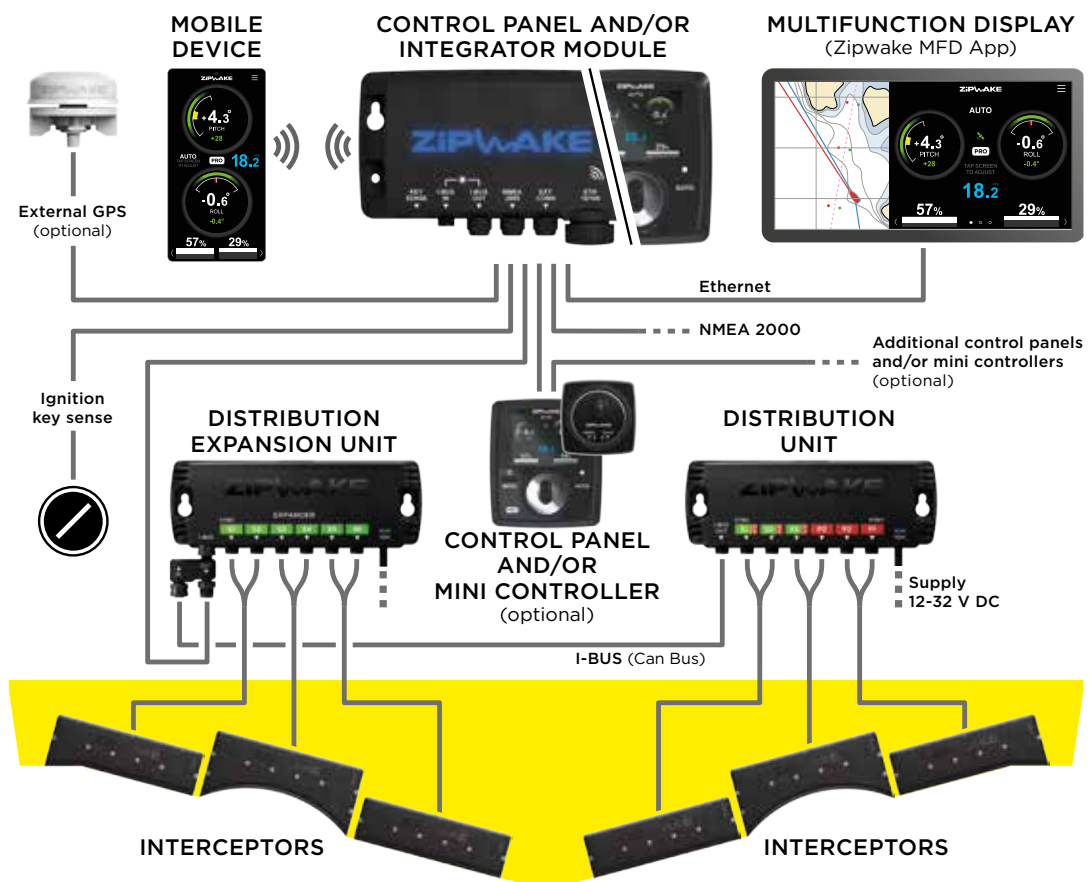

1.1 MOTION CONTROL FEATURES

Mode	Motion	Feature	Standard	Future
Automatic	Pitch	Pro active pitch control	PRO	
		Pitch-offset control with quick save	PRO	
		Curve-based pitch control	•	
		Easy manipulation of pitch control curve	•	
		Basic pitch control curve from boat dimensions	•	
	Roll	Pro active roll control	PRO	
		Pro balanced turns	PRO	
		Advanced turn recognition	PRO	
		Roll angle offset	PRO	
		Roll sensitivity control	•	
Yaw	Auxiliary steering, controllable by other onboard system		•	
Manual	Pitch	Trim control	•	
		Auxiliary trim control by classic switches	•	
		Speed-progressive control wheel	•	
	Roll	List control	•	
		Auxiliary list control by classic switches	•	
		Wake shaping	PRO	
		Speed-progressive control wheel	•	
	Yaw	Steering control (calm sea or emergency steering)	•	
		Speed-progressive control wheel	•	

For details, refer to the Operator's Manual.

Pro active pitch

Pro active pitch control refers to rapid automated adjustment of the vessel's pitch angle to optimize performance, fuel efficiency, stability, and comfort. Using the system's sensors, the active pitch controller continuously modifies the interceptors' extensions to dampen pitch motions and hold the boat at its optimum running trim angle.

Pitch offset

The pitch offset function allows adjustment of the vessel's target pitch angle or interceptor extension (relative to predetermined settings). This enables the operator to easily fine-tune performance under varying sea states and load conditions. The system also include means for easy permanent adjustment of predetermined settings.

Pro active roll

Pro active roll control refers to rapid automated adjustment of the vessel's roll angle to optimize performance, stability, and comfort. Using the system's sensors, the active roll controller continuously modifies the interceptors' extensions to dampen roll motions and keep the boat level.

Pro balanced turns

The pro balanced turn function is designed to optimize comfort on board by maintaining the ideal heeling angle throughout turns, thereby eliminating the centrifugal forces experienced by the passengers. The function includes advanced turning recognition using the system's built-in sensors, avoiding awkward integration with the steering system.

Roll angle offset

The roll controller's target angle can be offset to suit specific sea conditions. Running with a slight list of a few degrees can result in a drier ride.

Roll sensitivity control

The system allows adjustment of roll control responsiveness, which can be useful for optimizing system performance in different sea conditions or for use in combination with the auto-pilot.

Auxiliary trim/list control by classic switches

The integrator module supports manual control of trim and list using rocker switches.

Wake shaping

Interceptors are an ideal way to fine-tune the shape of the wake when wake surfing. The system's wake-shaping feature allows easy control of the interceptor blades, positioning them precisely to create the ideal wake shape on either side of the wave behind the boat.

Steering control

The system's steering mode allows the roll wheel to act as the helm. Turning the wheel clockwise will steer the vessel towards starboard and vice versa. The feature can serve as backup steering in case the regular steering fails.

Speed-progressive control wheel

The intuitive control wheels of the Zipwake control panel and mini controller respond progressively to user input, i.e. the response of the control depends on how fast the wheels are turned; it also depends on boat speed, ensuring safe, effective manual pitch and roll control.

1.2 CONFIGURABLE LIFT FORCE ALLOCATION

The Series E Pro system allows customized allocation of control forces by setting active or inactive control of pitch, roll and yaw for each pair of port and starboard interceptors. A pair's function may also be swapped e.g. to mitigate roll-induced steering forces from another interceptor pair or pairs.

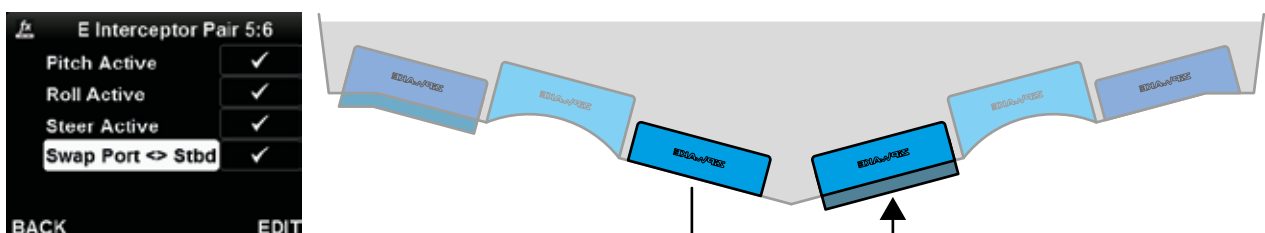

1.3 PRODUCTS AND PARTS OVERVIEW

Zipwake products and parts come as kit boxes, accessories or spare parts.

KIT BOXES

			Kit Box Contents							
			Kit Box Part No.	2022213	2022011	2022012	2022013	2022214	2022014	2022494
Model	Part No.	Description	KB400-E PRO	KB600-E PRO	KB800-E PRO	KB1000-E PRO	KB400-E PRO CHINE	KB600-E PRO CHINE	KB400-E PRO ROUND	
CP PRO	2022032	Control Panel Pro with Standard Cable 7 M	1	1	1	1	1	1	1	
EC5-M12	2011260	M12 Extension Cable 5 M	1	1	1	1	1	1	1	
DU PRO	2022033	Distribution Unit Pro with Power Cable 4 M	1	1	1	1	1	1	1	
IT400-E PRO	2022215	Interceptor 400 E Pro with Cable 3 M & Cable Cover	2							
IT600-E PRO	2022018	Interceptor 600 E Pro with Cable 3 M & Cable Cover		2						
IT800-E PRO	2022019	Interceptor 800 E Pro with Cable 3 M & Cable Cover			2					
IT1000-E PRO	2022020	Interceptor 1000 E Pro with Cable 3 M & Cable Cover				2				
IT400-E PRO CHINE PORT	2022216	Interceptor 400 E Pro Chine Port side with Cable 3 M & Cable Cover					1			
IT400-E PRO CHINE STBD	2022217	Interceptor 400 E Pro Chine Starboard side with Cable 3 M & Cable Cover					1			
IT600-E PRO CHINE PORT	2022024	Interceptor 600 E Pro Chine Port side with Cable 3 M & Cable Cover						1		
IT600-E PRO CHINE STBD	2022025	Interceptor 600 E Pro Chine Starboard side with Cable 3 M & Cable Cover						1		
IT400-E PRO ROUND R1000	2022491	Interceptor 400 E Pro Round R1000 with Cable 3 M & Cable Cover							2	

			Kit Box Contents							
			Kit Box Part No.	2022270	2022271	2022272	2022273	2022274	2022275	2022495
Model	Part No.	Description	KBI400-E PRO	KBI600-E PRO	KBI800-E PRO	KBI1000-E PRO	KBI400-E PRO CHINE	KBI600-E PRO CHINE	KBI400-E PRO ROUND	
IM	2012241	Integrator Module	1	1	1	1	1	1	1	
SC15-M12	2012037	M12 Standard Cable 15 M	1	1	1	1	1	1	1	
DU PRO	2022033	Distribution Unit Pro with Power Cable 4 M	1	1	1	1	1	1	1	
IT400-E PRO	2022215	Interceptor 400 E Pro with Cable 3 M & Cable Cover	2							
IT600-E PRO	2022018	Interceptor 600 E Pro with Cable 3 M & Cable Cover		2						
IT800-E PRO	2022019	Interceptor 800 E Pro with Cable 3 M & Cable Cover			2					
IT1000-E PRO	2022020	Interceptor 1000 E Pro with Cable 3 M & Cable Cover				2				
IT400-E PRO CHINE PORT	2022216	Interceptor 400 E Pro Chine Port side with Cable 3 M & Cable Cover					1			
IT400-E PRO CHINE STBD	2022217	Interceptor 400 E Pro Chine Starboard side with Cable 3 M & Cable Cover					1			
IT600-E PRO CHINE PORT	2022024	Interceptor 600 E Pro Chine Port side with Cable 3 M & Cable Cover						1		
IT600-E PRO CHINE STBD	2022025	Interceptor 600 E Pro Chine Starboard side with Cable 3 M & Cable Cover						1		
IT400-E PRO ROUND R1000	2022491	Interceptor 400 E Pro Round R1000 with Cable 3 M & Cable Cover							2	

ACCESSORIES AND SPARE PARTS

Model	Part No.	Description	Accessory	Spare Part
IM	2012241	Integrator Module	●	●
MC	2012401	Mini Controller with Standard Cable 3 M	●	●
CP PRO	2022032	Control Panel E Pro with Standard Cable 7 M	●	●
DU PRO	2022033	Distribution Unit Pro with Power Cable 4 M	●	●
DU-EX PRO	2022034	Distribution Expansion Unit Pro with Power Cable 4 M	●	●
IT400-E PRO	2022215	Interceptor 400 E Pro with Cable 3 M & Cable Cover	●	●
IT600-E PRO	2022018	Interceptor 600 E Pro with Cable 3 M & Cable Cover	●	●
IT800-E PRO	2022019	Interceptor 800 E Pro with Cable 3 M & Cable Cover	●	●
IT1000-E PRO	2022020	Interceptor 1000 E Pro with Cable 3 M & Cable Cover	●	●
IT400-E PRO CHINE PORT	2022216	Interceptor 400 E Pro Chine Port side with Cable 3 M & Cable Cover	●	●
IT400-E PRO CHINE STBD	2022217	Interceptor 400 E Pro Chine Starboard side with Cable 3 M & Cable Cover	●	●
IT600-E PRO CHINE PORT	2022024	Interceptor 600 E Pro Chine Port side with Cable 3 M & Cable Cover	●	●
IT600-E PRO CHINE STBD	2022025	Interceptor 600 E Pro Chine Starboard side with Cable 3 M & Cable Cover	●	●
IT600-E PRO TUNNEL R500	2022021	Interceptor 600 E Pro Tunnel R500 with Cable 3 M & Cable Cover	●	●
IT600-E PRO TUNNEL R600	2022022	Interceptor 600 E Pro Tunnel R600 with Cable 3 M & Cable Cover	●	●
IT600-E PRO TUNNEL R800	2022023	Interceptor 600 E Pro Tunnel R800 with Cable 3 M & Cable Cover	●	●
IT400-E PRO ROUND R1000	2022491	Interceptor 400 E Pro Round R1000 with Cable 3 M & Cable Cover	●	●
EC1.5-M12	2011258	M12 Extension Cable 1.5 M	●	●
EC3-M12	2011259	M12 Extension Cable 3 M	●	●
EC5-M12	2011260	M12 Extension Cable 5 M	●	●
EC10-M12	2011261	M12 Extension Cable 10 M	●	●
EC15-M12	2012038	M12 Extension Cable 15 M	●	●
EC20-M12	2012039	M12 Extension Cable 20 M	●	●
SC3-M12	2012408	M12 Standard Cable 3 M	●	●
SC7-M12	2011257	M12 Standard Cable 7 M	●	●
SC15-M12	2012037	M12 Standard Cable 15 M	●	●
CC-EX	2012036	Cable Cover Extension E Kit	●	●
	2011381	Control Panel Cover, White	●	●
	2011382	Control Panel Cover, Light gray	●	●
CP COVER	2011383	Control Panel Cover, Mid gray	●	●
	2011384	Control Panel Cover, Dark gray	●	●
	2011385	Control Panel Cover, Black	●	●
CP ALU FRAME	2011281	Control Panel Alu Frame	●	●
GPU	2011240	Global Positioning Unit with Cable 5 M & Mount Kit	●	●
GB	2011622	Gimbal Bracket for Control Panel	●	●
SU-E PRO	2022035	Servo Unit E Pro with Cable 3 M		●
SU-400E PRO	2022235	Servo Unit 400 E Pro with Cable 3 M		●
IT400-E FRONT	2012218	Interceptor 400 E Front		●
IT600-E FRONT	2012045	Interceptor 600 E Front		●
IT800-E FRONT	2012046	Interceptor 800 E Front		●
IT1000-E FRONT	2012047	Interceptor 1000 E Front		●
IT400-E CHINE PORT FRONT	2012219	Interceptor 400 E Chine Port Side Front		●
IT400-E CHINE STBD FRONT	2012220	Interceptor 400 E Chine Starboard Side Front		●
IT600-E CHINE PORT FRONT	2012051	Interceptor 600 E Chine Port Side Front		●
IT600-E CHINE STBD FRONT	2012052	Interceptor 600 E Chine Starboard Side Front		●
IT600-E TUNNEL R500 FRONT	2012048	Interceptor 600 E Tunnel R500 Front		●
IT600-E TUNNEL R600 FRONT	2012049	Interceptor 600 E Tunnel R600 Front		●
IT600-E TUNNEL R800 FRONT	2012050	Interceptor 600 E Tunnel R800 Front		●
IT400-E ROUND R1000 FRONT	2012493	Interceptor 400 E Round R1000 Front		●

PRO UPGRADE

Model	Part No.	Description	Accessory	Spare Part
UPGRADE KIT 400E PRO	2022522	Upgrade Kit E Pro with one DU PRO and four SU-E Pro	●	
UPGRADE KIT 400E PRO	2022523	Upgrade Kit 400E Pro with one DU PRO and two SU-400E Pro	●	
UPGRADE KIT 400E PRO QUAD	2022525	Upgrade Kit E Pro Quad with one DU PRO and four SU-400E Pro	●	





2 KIT BOXES

Kit boxes include all the parts needed to install a Dynamic Trim Control System with one pair of ultra-fast straight, chine or round interceptors. There are seven standard kit boxes, each with a stylish, user-friendly, intuitive control panel, and seven kit boxes for integration with a module for hard-wired system integration and wireless communication.



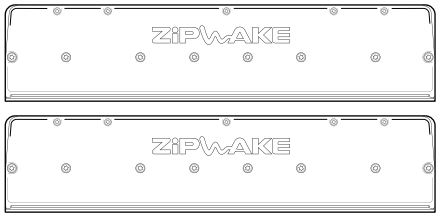

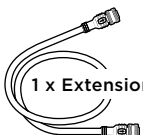

2.1 KIT BOX CONTENTS

Standard kit box contains:

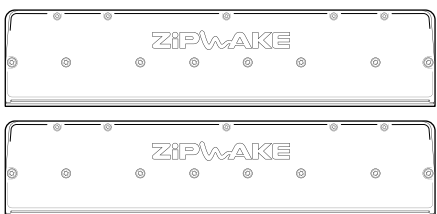
<p>INTERCEPTOR</p>  <p>2 x Interceptors with Cable 3 m & Cable Cover</p>	<p>DISTRIBUTION UNIT</p>  <p>1 x Distribution Unit with Power Cable 4 m</p>	<ul style="list-style-type: none"> + Operator's Manual + Warranty Card + Installation Guide + Drill Templates + Mounting Screws + Operator's Quick Guide + Startup Checklist  <p>1 x Extension Cable 5 m</p>
<p>CONTROL PANEL</p>  <p>1 x Control Panel with Standard Cable 7 m</p>		

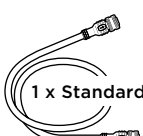
Kit box for integration contains:

<p>INTERCEPTOR</p>  <p>2 x Interceptors with Cable 3 m & Cable Cover</p>	<p>DISTRIBUTION UNIT</p>  <p>1 x Distribution Unit with Power Cable 4 m</p>	<ul style="list-style-type: none"> + Operator's Manual + Warranty Card + Installation Guide + Drill Templates + Mounting Screws + Operator's Quick Guide + Startup Checklist  <p>1 x Standard Cable 15 m</p>
<p>INTEGRATOR MODULE</p>  <p>1 x Integrator Module</p>		

Any base installation can be expanded with one center-mounted Series E Pro dual-servo interceptor or up to two Series E Pro single-servo interceptors or two Series S Pro interceptors, without any need for additional connectors or power supply.

2.2 SPECIFICATIONS

Standard kit box:

Model	KB400-E PRO	KB600-E PRO	KB800-E PRO	KB1000-E PRO	KB400-E PRO CHINE	KB600-E PRO CHINE	KB400-E PRO ROUND	
Width	752 (29.6)	752 (29.6)	930 (36.6)	1130 (44.5)	752 (29.6)	752 (29.6)	752 (29.6)	mm (in)
Depth	192 (7.6)	192 (7.6)	192 (7.6)	192 (7.6)	192 (7.6)	192 (7.6)	192 (7.6)	mm (in)
Height	452 (17.8)	452 (17.8)	458 (18)	458 (18)	452 (17.8)	452 (17.8)	452 (17.8)	mm (in)
Weight	17.1 (37.7)	22 (48.5)	26.8 (59.1)	32.8 (72.3)	17.4 (38.4)	22.3 (49.2)	17.5 (38.6)	kg (lbs)

Kit box for integration:

Model	KBI400-E PRO	KBI600-E PRO	KBI800-E PRO	KBI1000-E PRO	KBI400-E PRO CHINE	KBI600-E PRO CHINE	KBI400-E PRO ROUND	
Width	752 (29.6)	752 (29.6)	930 (36.6)	1130 (44.5)	752 (29.6)	752 (29.6)	752 (29.6)	mm (in)
Depth	192 (7.6)	192 (7.6)	192 (7.6)	192 (7.6)	192 (7.6)	192 (7.6)	192 (7.6)	mm (in)
Height	452 (17.8)	452 (17.8)	458 (18)	458 (18)	452 (17.8)	452 (17.8)	452 (17.8)	mm (in)
Weight	17.2 (37.9)	22.1 (48.7)	26.9 (59.3)	32.9 (72.5)	17.5 (38.6)	22.4 (49.4)	17.6 (38.8)	kg (lbs)

See section 1.3 for details of the contents of each kit box.

2.3 ORDERING DATA

Standard kit box:

Model	KB400-E PRO	KB600-E PRO	KB800-E PRO	KB1000-E PRO	KB400-E PRO CHINE	KB600-E PRO CHINE	KB400-E PRO ROUND
Part No.	2022213	2022011	2022012	2022013	2022214	2022014	2022494

Kit box for integration:

Model	KBI400-E PRO	KBI600-E PRO	KBI800-E PRO	KBI1000-E PRO	KBI400-E PRO CHINE	KBI600-E PRO CHINE	KBI400-E PRO ROUND
Part No.	2022270	2022271	2022272	2022273	2022274	2022275	2022495

3 CONTROL PANEL

Zipwake's stylish control panel is carefully designed to be user-friendly and intuitive to allow the driver to focus on the right thing – enjoying the boat ride!

The panel's two unique control wheels provide easy, quick and intuitive manual control of running trim, heel or heading. However, the system normally operates in automatic control mode, which is enabled by a single press on the AUTO button. In this mode, the built-in high-frequency GPS, 3D gyro sensors and robust motion controller automatically ensure dynamic elimination of uncomfortable and dangerous boat pitch and roll.

The system provides continuous feedback of boat speed, pitch and roll angle, as well as the interceptors' positions, on a 2.8" sunlight-readable wide viewing color display.



The panel's waterproof design withstands harsh marine conditions in open boats or on a flybridge. The sockets for connecting peripherals are located on the rear of the panel. In addition to connectors for the system's distribution unit and multiple control panels, external GPS and NMEA2000 equipment can be connected. The system can also be connected to the ignition key for automatic system power-on. A waterproof cap conceals the USB interface that allows for future software upgrades and ensures that the Zipwake Dynamic Trim Control System is future-proof.

3.1 FEATURES



- Fully automatic
 - Dynamic pitch and roll control
 - Steering and turn enhancement
- Built-in GPS and motion sensors
- Unique and intuitive 3D controls
- Sunlight readable color display
- Instant state user feedback
- Auto power on/off via ignition key sense
- Full range of electrical interfaces
- Waterproof
- Auto dimming / night mode
- Upgradable via USB stick
- Supports up to 3 additional control panels in the system
- Surface, flush or gimbal bracket mount
- Manages installation configurations from 1 to 6 pro interceptors
- Allows configuration of interceptor pair function
- Auto cleaning
 - Selectable periodic cleaning cycle
 - Prevents fouling inside the interceptor
- Monitored and/or controlled from external devices, e.g. multifunction displays or plotters via its NMEA 2000 interface
- Can be combined with the integrator module

3.2 SPECIFICATIONS

Model	CP PRO
Display	2.8" IPS color TFT LCD, 320 x 240 pixels, double-sided, anti-reflection coated window
Internal sensors	5 Hz GPS, 3D Gyro, 3D Accelerometer, Ambient light
Operating voltage	12 - 32 V DC
Power consumption	10 W max
Operating temperature	-20° to +80°C (-4° to +176°F)
Storage temperature	-40° to +90°C (-40° to +194°F)
Waterproof rating	IP67 / IP64 (front / back)
Compass safe distance	0.5 m (1.7 ft)
Compliance	CE, FCC
Weight	0.22 kg (0.49 lbs)
Mounting	Surface, flush or gimbal bracket mount

3.3 INTERFACES

- I-BUS IN (CAN bus)
- I-BUS OUT (CAN bus)
- NMEA 2000
- Key sense
- USB device port (Type A)
- USB host port (Type B)
- External GPS (NMEA 0183 / RS232 auto baud-rate sensing)



3.4 DIMENSIONS

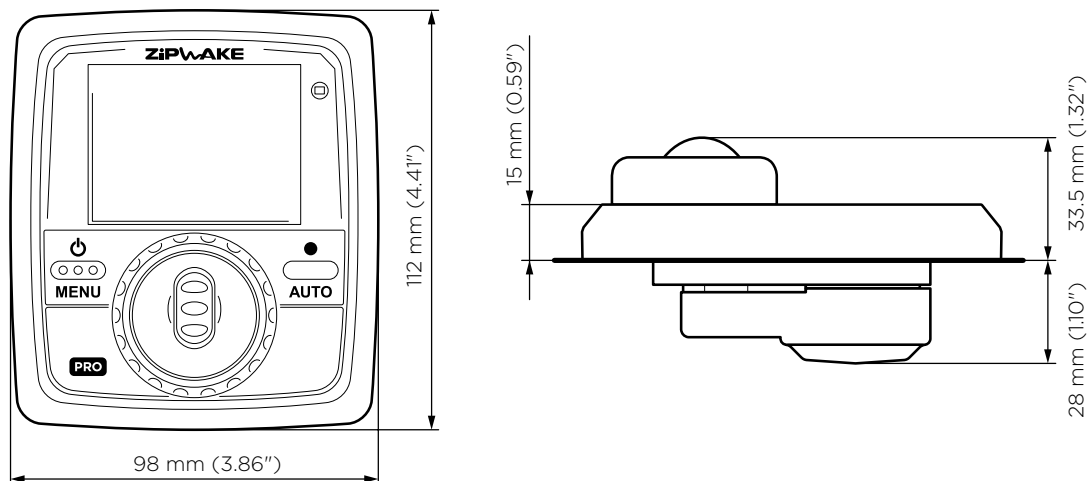

3.5 ORDERING DATA

Model	CP PRO
Part No.	2022032 with Standard Cable 7 m

- Included in kit boxes
- Available as an accessory
- Available as a spare part

4 INTEGRATOR MODULE

The Zipwake integrator module enables total integration and clean dashboard solutions by connecting the Zipwake system to multifunction displays (MFDs) and/or smart devices. The embedded Zipwake user interface provides intuitive, easy control without the need for a separate control panel, although any Zipwake system will allow up to 3 additional control panels and/or mini controllers for anyone wanting both touch buttons and Zipwake's unique control wheels for ultimate manual control.



The integrator module supports connections to a wide range of MFD brands/models via an ethernet interface. Its wireless interface enables connection to smartphones and tablets by means of Zipwake's app for wireless views, control, configuration and software updates.

The integrator also includes a CAN interface for further external system integration.

The integrator module has built-in motion sensors that also use GPS data acquired from either an NMEA 2000 connected network, an external GPS antenna or an extra control panel to ensure precise and dynamic control of the boat's pitch and roll. The module can be oriented in any direction and its rugged, waterproof design allows for flexible installation e.g. behind the helm/dash, on the flybridge or in the engine room. It comes with a special ethernet connector collar that makes sealing standard ethernet cables easy.

The integrator module is compatible with all Zipwake system components and is available as an accessory, a spare part or included in kit boxes for integration (refer to section 1.2).

4.1 FEATURES

- Fully automatic
 - Dynamic pitch and roll control
 - Steering and turn enhancement
- Motion sensors and magnetic compass
- Instant user feedback
- Auto power on/off via ignition key sense
- Waterproof design
 - Standard ethernet cable sealed by waterproof ethernet connector collar
- RGB LED status indicators for each interface
- Wireless upgradable via smartphones/tablets
- Supports up to three additional control panels and/or mini controllers in the system
- Compatible with all Zipwake system components
- Manages installation configurations from 1 to 6 pro interceptors

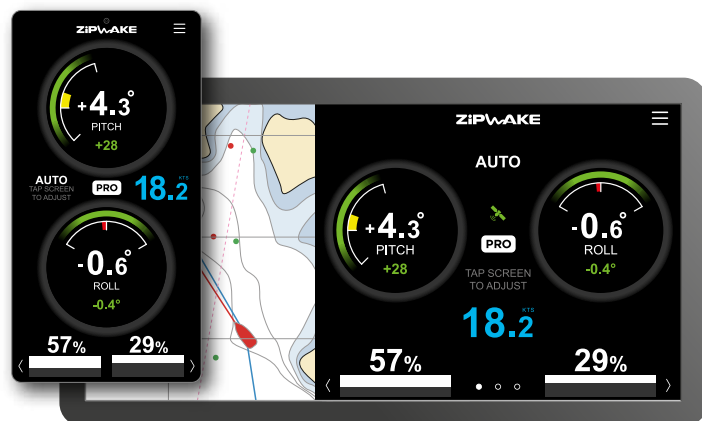

- Allows configuration of interceptor pair function
- Auto cleaning
 - Selectable periodic cleaning cycle
 - Prevents fouling inside the interceptor
- Monitored and/or controlled from external devices
 - Multifunction displays (MFDs) via ethernet
 - Smartphones/tablets via wireless interface
 - Plotters via NMEA 2000 interface

4.2 SPECIFICATIONS

Model	IM
Indicators	RGBW LEDs for each communication interface (x4) RGBW backlit logo
Internal sensors	3D Gyro, 3D Accelerometer, Compass
Operating voltage	12 - 32 V DC
Power consumption	4 W max
Operating temperature	-20° to +60°C (-4° to +140°F)
Storage temperature	-40° to +90°C (-40° to +194°F)
Waterproof rating	IP67
Compass safe distance	0.5 m (1.7 ft)
Compliance	CE, FCC, SAE J1171 Ignition Protected
Weight	0.35 kg (0.77 lbs)

4.3 INTERFACES

- I-BUS IN (CAN bus)
- I-BUS OUT (CAN bus)
- NMEA 2000
- Key sense
- External connection
 - GPS (NMEA 0183 / RS232)
 - CAN (J1939)
- Ethernet (10/100G)
- Wi-Fi

4.4 DIMENSIONS

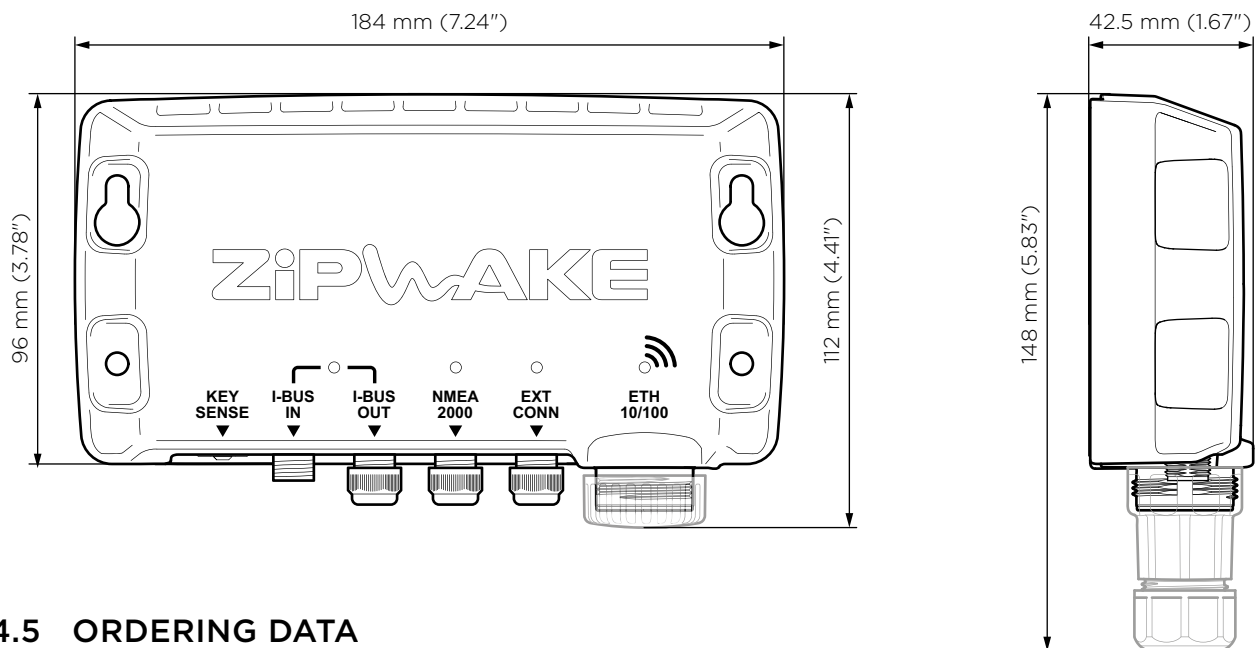

4.5 ORDERING DATA

Model	IM
Part No.	2012241

- Included in kit boxes for integration
- Available as an accessory
- Available as a spare part

5 MINI CONTROLLER

The Zipwake mini controller is the perfect complement for any Zipwake system with integrator module and MFDs. The small and intuitive mini controller provides easy manual control of running trim, heel or heading as well as system settings the same way as the well proven control panel.

The mini controller is designed to withstand harsh marine conditions in open boats or on a flybridge and can be mounted in any position suited for the helmsman. The mini controller can be connected to the integrator module and/or a control panel as well as the ignition key for automatic system power-on.



5.1 FEATURES

- Unique and intuitive 3D controls
- Auto power on/off via ignition key sense
- Surface or flush mount
- LED status indication

5.2 INTERFACES

- I-BUS IN (CAN bus)
- I-BUS OUT (CAN bus)
- Key sense

5.3 SPECIFICATIONS

Model	MC
Indicators	RGBW LEDs
Operating voltage	12 - 32 V DC
Power consumption	2 W max
Operating temperature	-20° to +80°C (-4° to +176°F)
Storage temperature	-40° to +90°C (-40° to +194°F)
Waterproof rating	IP67
Compass safe distance	0.5 m (1.7 ft)
Compliance	CE, FCC
Weight	0.10 kg (0.22 lbs)

5.4 DIMENSIONS

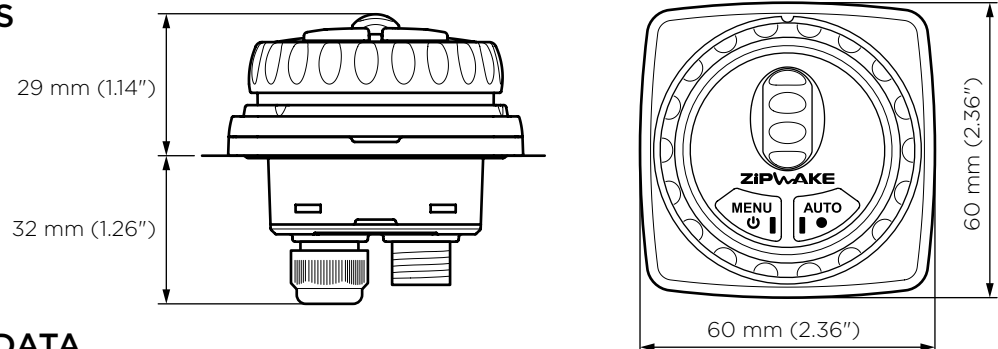

5.5 ORDERING DATA

Model	MC
Part No.	2012401 with Standard Cable 3 m

- Available as an accessory
- Available as a spare part



6 INTERCEPTORS

The Series E Pro interceptors with a 60 mm full stroke in just 0.3 seconds provide a blade rate sufficient to perfectly balance most high-speed craft. The four straight, one rounded, three tunnel, and four chine models make for the perfect transom arrangement. Because the large, modular design is ideal for standardized production, the interceptors are durable, affordable and particularly well adapted to any planing or semi-planing boat up to 30 m (100 ft).



All components have been meticulously engineered to withstand impact and avoid water ingress, minimizing the risk of costly maintenance and downtime. The ultra-fast blade actuation takes place by way of calibration-free submersible electric pro servos in the interceptor unit. Natural water cooling provides excellent working conditions for the brushless DC servo motors, which run on 36 volts.

Installation is made easy with an integral mounting plate and the option of a concealed or above-waterline, self-sealing, thru-hull cable fitting. The preferred mounting option is achieved by simply routing the servo cable(s) as shown below. Each interceptor comes with the thru-hull cable fitting, cable cover and a practical drill template.

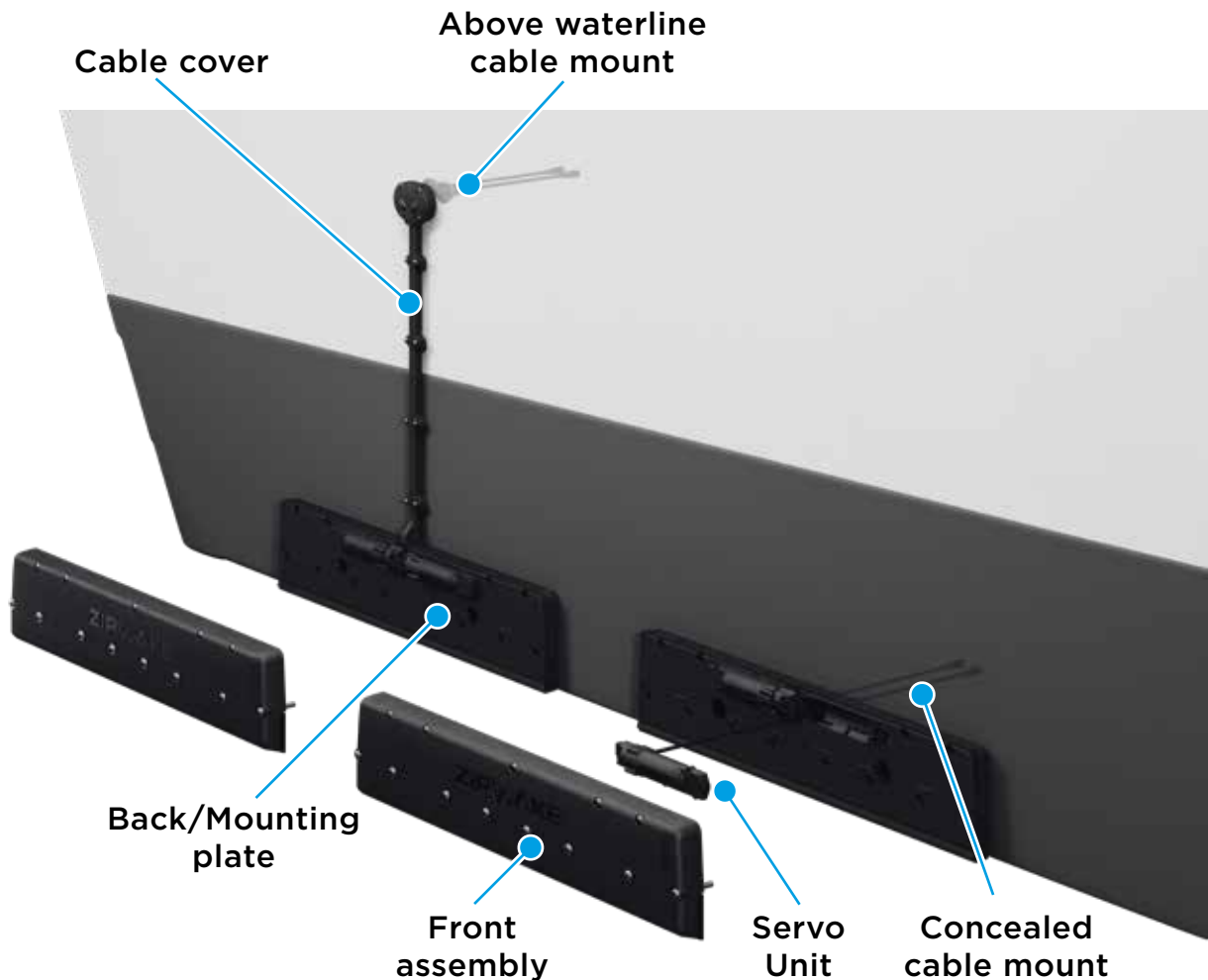

For best effect, different size interceptors can be combined to span as much of the transom edge as possible. A full beam is always the optimal arrangement from a lift-to-drag ratio point of view.

Combine any interceptors to get the perfect system for multihull boats e.g. power catamarans.



Tunnel interceptors for mounting above propeller tunnels

Tunnel-shaped interceptors provide the perfect lift-force solution for hulls with propeller tunnels. In contrast to straight interceptors, the tunnel interceptor's constant radius curvature allows mounting above the propeller tunnel to fully or partially use the otherwise unutilized part of the beam for lift generation.



The three tunnel models with different radius, R500, R600 and R800, make sure that most large boat propeller tunnels can be covered with negligible deviation between hull and interceptor curvature. Tunnel interceptors can be included in new installations, or retro-fitted to systems already installed.



Rounded interceptor for convex hulls

A rounded interceptor with radius R1000 is the perfect choice for vessels with rounded hulls.

The curved bottom and blade of the interceptor allow it to be mounted closer to the edge of a convex hull making it more efficient than a straight one.

Combine it with any other interceptor for the best configuration.

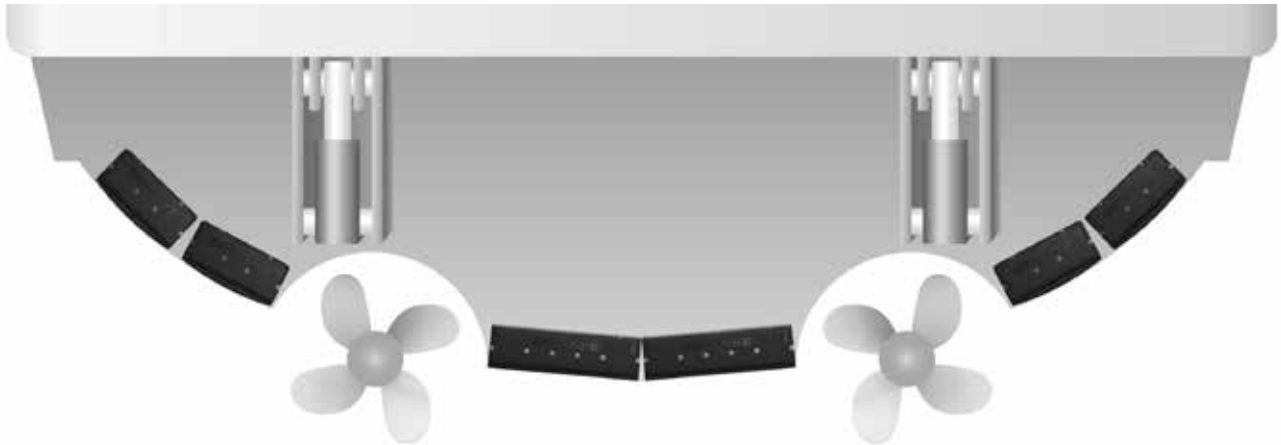

Chine interceptors for maximum lift

Chine interceptors provide a unique means of maximizing pitch and roll motion control by utilizing the furthest outboard surfaces of the hull bottom for lift generation.

As a rule, the lift effect of a chine interceptor matches the lift of a straight interceptor one size larger mounted inboard of the chine, making them the go-to choice when selecting interceptors.



Chine interceptors are particularly useful when transom space is limited abeam of swim platform lifts, waterjets, surface drives, or outboards.





ZIPWAKE

600E

6.1 FEATURES



- True outboard mount
- Modular design
- Ultra-fast blade actuation
- Straight, rounded, tunnel and chine models
- Integrated mounting plate
- Thru-hull fitting options
 - Above waterline
 - Concealed behind interceptor
- Submersible servo units
 - Brushless 36V DC servo motor(s)
 - High-precision positioning
 - Calibration free
 - Durable and accessible
- Auto cleaning
 - Periodically selectable cleaning cycle
 - Prevents fouling inside the interceptor
- No corrosive materials



6.2 SPECIFICATIONS

Model		IT400-E PRO	IT600-E PRO	IT800-E PRO	IT1000-E PRO
Length	mm (in)	400 (15.7)	600 (23.6)	800 (31.5)	1000 (39.4)
Weight	kg (lbs)	5.0 (11.0)	7.3 (16.1)	9.2 (20.3)	11.5 (25.4)
Servo units		Single	Dual	Dual	Dual

Model		IT400-E PRO ROUND R1000	IT600-E PRO TUNNEL R500	IT600-E PRO TUNNEL R600	IT600-E PRO TUNNEL R800
Length	mm (in)	400 (15.7)	600 (23.6)	600 (23.6)	600 (23.6)
Weight	kg (lbs)	5.2 (11.5)	8.4 (18.5)	8.2 (18.1)	7.9 (17.4)
Servo units		Single	Dual	Dual	Dual

Model		IT400-E PRO CHINE PORT	IT400-E PRO CHINE STBD	IT600-E PRO CHINE PORT	IT600-E PRO CHINE STBD
Length	mm (in)	400 (15.7)	400 (15.7)	600 (23.6)	600 (23.6)
Weight	kg (lbs)	5.1 (11.2)	5.1 (11.2)	7.4 (16.3)	7.4 (16.3)
Servo units		Single	Single	Dual	Dual

Max. boat speed	60 knots
Blade stroke	60 mm (2.4 in)
Blade rate	200 mm/s (7.9 in/s)
Thru-hull cable fitting	Concealed or above waterline
Servo actuator	SU-E PRO (dual-servo interceptors) SU-400E PRO (single-servo interceptors)
Cable length	3 m (10 ft), extendable up to 6 m (20 ft)
Cable material	PUR
Connector	M12 5-pin circular
Connector diameter	14.5 mm (0.57 in)
Operating voltage	36 V DC
Power consumption	35 W max/servo unit
Operating temperature	0° to +40°C (+32° to +104°F)
Storage temperature	-40° to +90°C (-40° to +194°F)
Waterproof rating	IP68 5 m (16 ft)
Compliance	CE, FCC

6.3 DIMENSIONS

IT400-E PRO

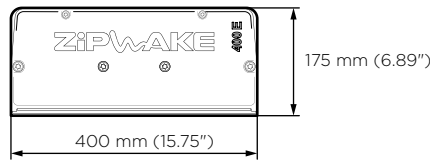

IT600-E PRO

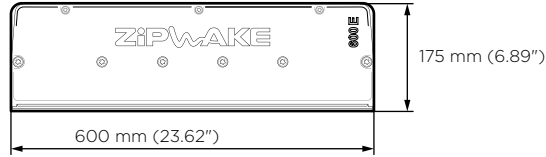

IT800-E PRO

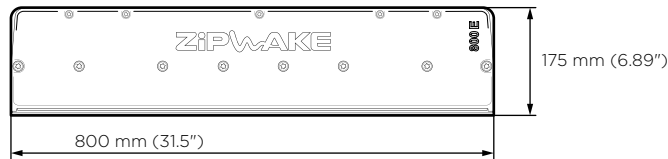

IT1000-E PRO

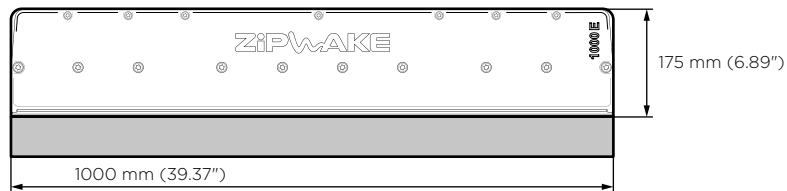

**IT400-E PRO
ROUND R1000**

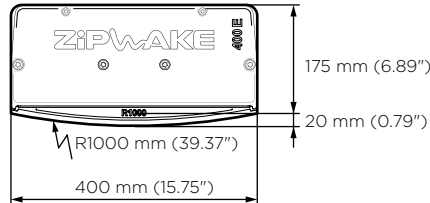

**IT600-E PRO
TUNNEL R500**

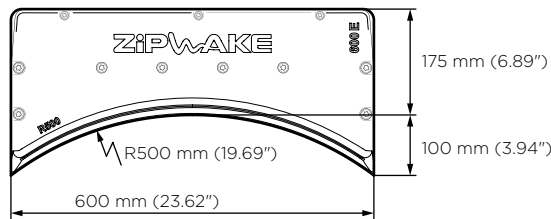

**IT600-E PRO
TUNNEL R600**

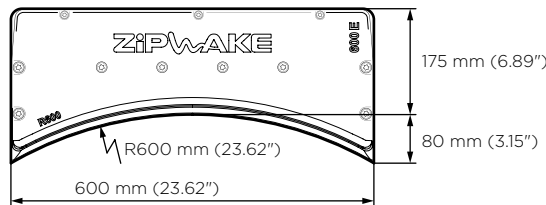

**IT600-E PRO
TUNNEL R800**

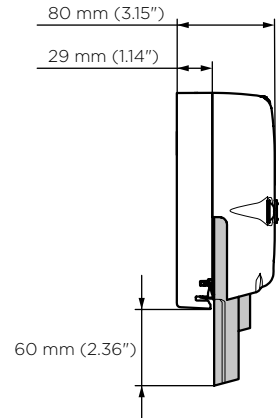
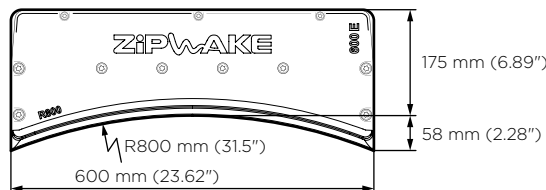

**IT400-E PRO
CHINE PORT**

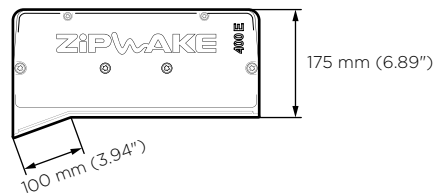

**IT400-E PRO
CHINE STBD**

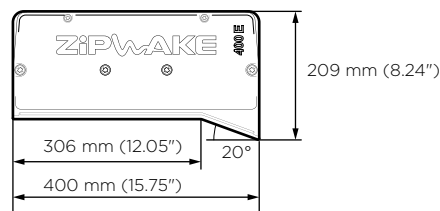

**IT600-E PRO
CHINE PORT**

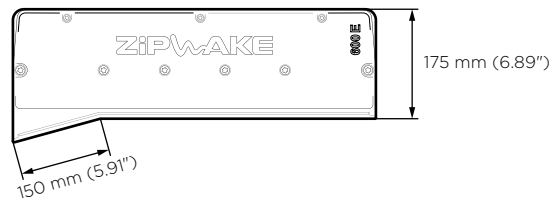

**IT600-E PRO
CHINE STBD**

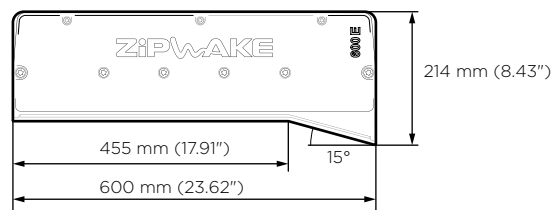

6.4 ORDERING DATA

Model	IT400-E PRO	IT600-E PRO	IT800-E PRO	IT1000-E PRO	IT400-E PRO ROUND R1000
Part No.	2022215	2022018	2022019	2022020	2022491
	Comes with Cable 3 m and Cable Cover				

Model	IT400-E PRO CHINE PORT	IT400-E PRO CHINE STBD	IT600-E PRO CHINE PORT	IT600-E PRO CHINE STBD
Part No.	2022216	2022217	2022024	2022025
	Comes with Cable 3 m and Cable Cover			

- Included in kit boxes
- Available as an accessory
- Available as a spare part

Model	IT600-E PRO TUNNEL R500	IT600-E PRO TUNNEL R600	IT600-E PRO TUNNEL R800
Part No.	2022021	2022022	2022023
	Comes with Cable 3 m and Cable Cover		

- Available as an accessory
- Available as a spare part

7 DISTRIBUTION UNITS

The distribution unit (DU PRO) with built-in voltage boost circuitry supplies the servo units with 36V DC power. It can accommodate up to three Series E Pro dual-servo interceptors or six single-servo Pro interceptors.

The unit is connected to the main control panel or integrator module. It is robust, waterproof, oil resistant and ignition protected for mounting in an engine room.

The power cable is included for easy connection to a battery. The distribution unit has built-in electrical protection, including its own automatic circuit breakers.

The system can be expanded with the distribution expansion unit (DU-EX PRO) to accommodate up to six Series E Pro dual-servo interceptors or any mix with single-servo pro interceptors.



7.1 SPECIFICATIONS

Model	DU PRO / DU-EX PRO
Supply voltage	12 - 32 V DC
Power consumption	10 W max
Protection fuse	Integrated and automatic
Power cable	Length 4 m (13 ft ft), Diameter 9 mm (0.35 in), 12 AWG
Operating temperature	-20° to +85°C (-4° to +185°F)
Storage temperature	-40° to +90°C (-40° to +194°F)
Waterproof rating	IP67 with cables and/or protective caps mounted
Oil resistance	Common engine fluids
Compliance	CE, FCC, SAE J1171 Ignition Protected
Weight	1.1 kg (2.4 lbs) including power cable

7.2 CONNECTORS

- Six servo connections
- I-BUS OUT
- 2-lead power cable

7.3 DIMENSIONS

DU PRO

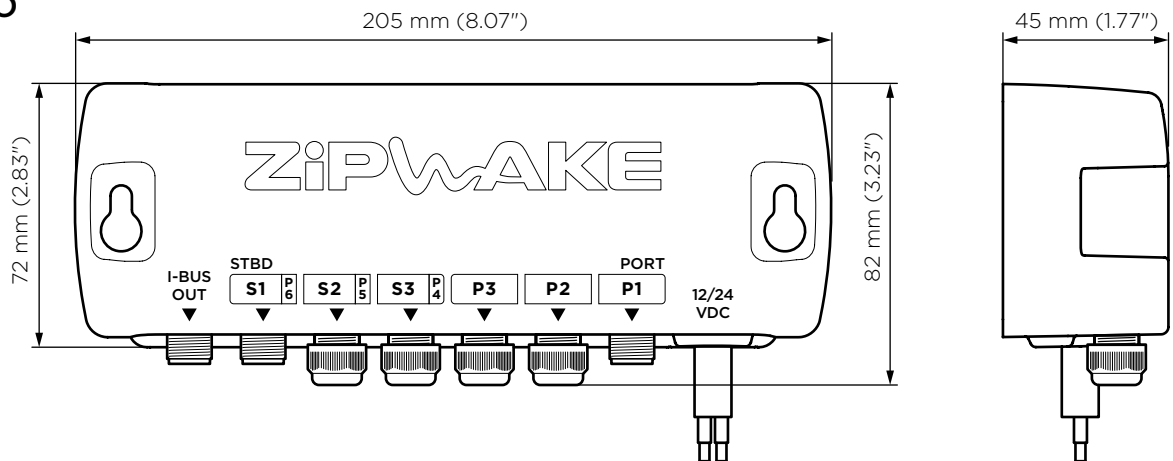

DU-EX PRO

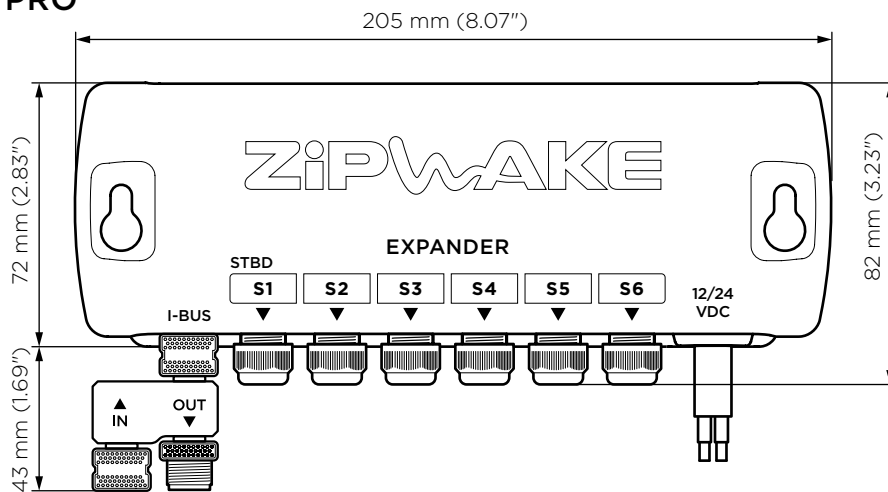

7.4 ORDERING DATA

Model	DU PRO	DU-EX PRO
Part No.	2022033 with Power Cable 4 m	2022034 with Power Cable 4 m

- Included in kit boxes
- Available as an accessory
- Available as a spare part

8 CABLES

Model	Description
SC3-M12	Standard Cable 3 m (10 ft)
SC7-M12	Standard Cable 7 m (23 ft)
SC15-M12	Standard Cable 15 m (49 ft)
EC1.5-M12	Extension Cable 1.5 m (5 ft)
EC3-M12	Extension Cable 3 m (10 ft)
EC5-M12	Extension Cable 5 m (16 ft)
EC10-M12	Extension Cable 10 m (33 ft)
EC15-M12	Extension Cable 15 m (49 ft)
EC20-M12	Extension Cable 20 m (65 ft)



The standard cables are used to connect the main control panel or the integrator module to the distribution unit, usually located on or near the transom and also to connect an extra control panel or mini controller. The standard cables can be extended by using any of the available extension cables. The servo unit cable can be extended using 1.5 m or 3 m extension cables. The total servo cable length must not exceed 6 m (20 ft).

8.1 SPECIFICATIONS

Model	SC3-M12	SC7-M12	SC15-M12	EC1.5-M12	EC3-M12	EC5-M12	EC10-M12	EC15-M12	EC20-M12	
Weight	kg (lbs)	0.16 (0.35)	0.38 (0.84)	0.80 (1.76)	0.09 (0.2)	0.16 (0.35)	0.26 (0.57)	0.50 (1.1)	0.75 (1.65)	1.05 (2.31)
Connectors	M12 5-pin circular									
Connector diameter	14.5 mm (0.57 in)									
Cable material	PVC									
Rated current	4 A									
Waterproof rating	IP67 when connected									
Operating temperature	-20° to +85°C (-4° to +185°F)									
Storage temperature	-40° to +90°C (-40° to +194°F)									
Oil resistance	Common engine fluids									
Compliance	CE, FCC									

8.2 ORDERING DATA

Model	SC3-M12	SC7-M12	SC15-M12	EC1.5-M12	EC3-M12	EC5-M12	EC10-M12	EC15-M12	EC20-M12
Part No.	2012408	2011257	2012037	2011258	2011259	2011260	2011261	2012038	2012039

- Available as an accessory
- Available as a spare part

9 CONTROL PANEL ALU FRAME

The control panel comes with a black frame and a wheel cap in a glossy chrome finish.

A conversion kit is available for customers who prefer a brushed aluminum finish. The kit comes with simple instructions to make replacement easy.



9.1 SPECIFICATIONS

Model	CP ALU FRAME
Surface appearance	Brushed aluminum
Items in kit	1 x frame, 1 x wheel cap, 1 x instruction
Weight	0.03 kg (0.06 lbs)

9.2 ORDERING DATA

Model	CP ALU FRAME
Part No.	2011281

- Available as an accessory
- Available as a spare part

10 CONTROL PANEL COVER

Weather cover for the control panel. Protects the display from the harsh marine environment when not in use. Fits standard surface-mounted control panels. Available in five different colors to blend in with other instruments.



10.1 SPECIFICATIONS

Model	CP COVER
Surface appearance	Five different colors, soft-touch
Weight	0.05 kg (0.11 lbs)

10.2 ORDERING DATA

Model	CP COVER				
Color	<input type="checkbox"/> WHITE	<input type="checkbox"/> LIGHT GRAY	<input type="checkbox"/> MID GRAY	<input type="checkbox"/> DARK GRAY	<input type="checkbox"/> BLACK
Part No.	2011381	2011382	2011383	2011384	2011385

- Available as an accessory
- Available as a spare part

11 CONTROL PANEL GIMBAL BRACKET

When space is limited, the gimbal bracket provides a useful installation option for the control panel. The gimbal bracket enables the control panel to be positioned at any angle between 0 and 360 degrees, and it comes with a cable gland that allows waterproof, open-sky installation.



11.1 SPECIFICATIONS

Model	GB
Items in kit	1 x bracket, 1 x frame, 10 x screws, 1 cable gland, 1 x instruction
Weight	0.12 kg (0.27 lbs)

11.2 DIMENSIONS

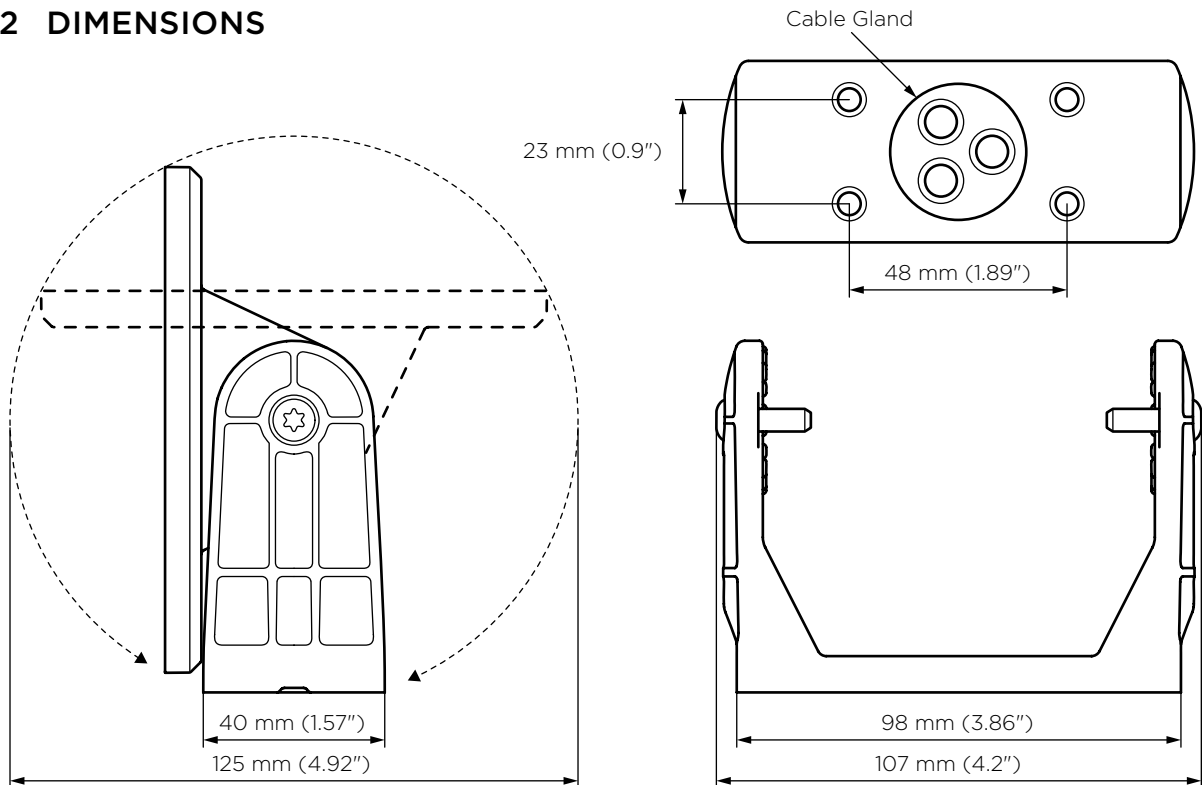

11.3 ORDERING DATA

Model	GB
Part No.	2011622

- Available as an accessory
- Available as a spare part

12 CABLE COVER EXTENSION KIT

The thru-hull cable fitting of Series E interceptors can either be concealed behind the interceptor or positioned above the waterline. If the above-waterline mount is preferred, the interceptors come with a thru-hull cover and a cable cover, and their accompanying cover bases.

A cable cover extension kit is available to provide flexible routing of the cable on the transom.



12.1 SPECIFICATIONS

Model	CC-EX
Items in kit	1 x cable cover with cover base 16 x screws
Weight	0.26 kg (0.57 lbs)

12.2 DIMENSIONS

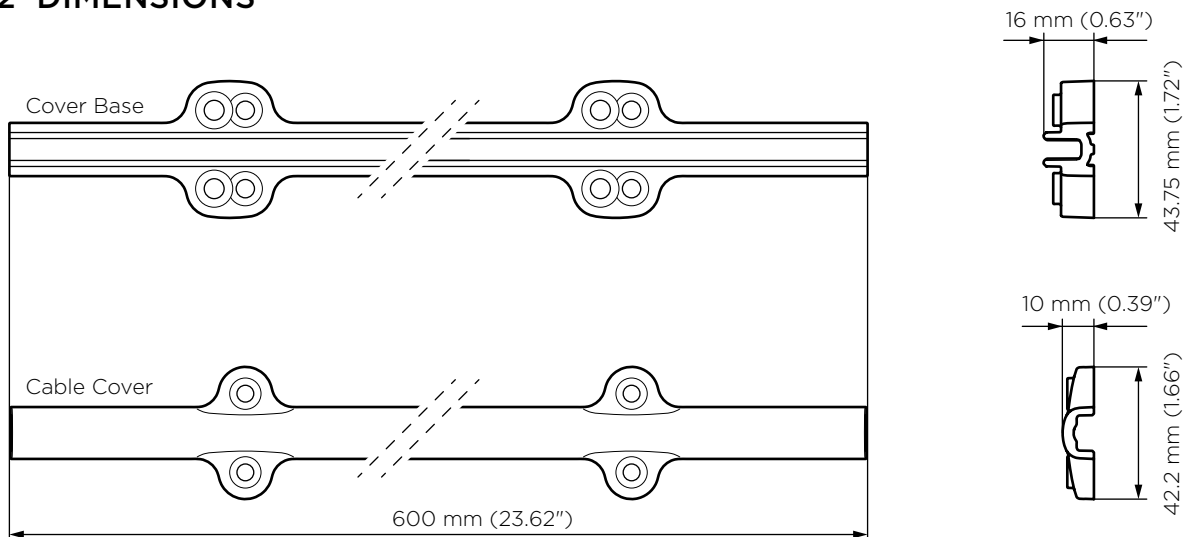

12.3 ORDERING DATA

Model	CC-EX
Part No.	2012036

- Available as an accessory
- Available as a spare part

13 SERVO UNIT

The Series E Pro submersible electrical servo unit fits inside the interceptor, where it drives with precision the mechanism that provides linear motion to the interceptor blades. For extended service life, the servo unit has double shaft seals and a precision-ground shaft in special high-grade stainless steel. The unit is ultra-fast, durable, calibration free and easy to install or replace. It comes with a rugged 3 m cable with a self-sealing thru-hull fitting.



13.1 SPECIFICATIONS

Model	SU-400E PRO	SU-E PRO
Interceptor (Pro models)	IT400-E, IT400-E chine and IT400-E round	IT600-E, IT800-E, IT1000-E, IT600-E chine and IT600-E tunnel models
Servo motor type	Brushless DC with Hall sensors	
Operating voltage	36 V DC	
Power consumption	35 W max	
Operating temperature	0° to +40°C (+32° to +104°F)	
Storage temperature	-40° to +90°C (-40° to +194°F)	
Waterproof rating	IP68 5 m (16 ft)	
Compliance	CE, FCC	
Cable length	3 m (10 ft), extendable up to 6 m (20 ft)	
Cable material	PUR	
Connector	M12 5-pin circular	
Connector diameter	14.5 mm (0.57 in)	
Weight	0.7 kg (1.54 lbs) including cable	

13.2 ORDERING DATA

Model	SU-400E PRO	SU-E PRO
Part No.	2022235	2022035
	Comes with Cable 3 m	

- Available as a spare part

14 INTERCEPTOR FRONTS

A front assembly comprises the interceptor's front housing, blade and assisting roller blade, the small parts that deal with blade linear motion and the set of screws required to mount the front to the back plate.



The front assemblies of the interceptors have been designed to mitigate further damage to the interceptor in the rare event of contact with floating debris. Each interceptor model's front assembly is therefore available as a spare part.

14.1 SPECIFICATIONS

Refer to interceptor specifications in section 6.2.

14.2 DIMENSIONS

Refer to interceptor dimensions in section 6.3.

14.3 ORDERING DATA

Model	IT400-E FRONT	IT600-E FRONT	IT800-E FRONT	IT1000-E FRONT
Part No.	2012218	2012045	2012046	2012047

- Available as a spare part

Model	IT400-E ROUND R1000 FRONT	IT600-E TUNNEL R500 FRONT	IT600-E TUNNEL R600 FRONT	IT600-E TUNNEL R800 FRONT
Part No.	2012493	2012048	2012049	2012050

- Available as a spare part

Model	IT400-E CHINE PORT FRONT	IT400-E CHINE STBD FRONT	IT600-E CHINE PORT FRONT	IT600-E CHINE STBD FRONT
Part No.	2012219	2012220	2012051	2012052

- Available as a spare part

15 EXTERNAL GPS ANTENNA

The Zipwake external GPS antenna is a 5Hz, 20-channel receiver with excellent reception that provides accurate and rapid vessel position and speed updates. Vessel speed is a necessary input for the Zipwake's automatic motion controller. The antenna has a rugged construction, is fully waterproof and can be mast or surface mounted on any vessel.



15.1 APPLICATION

The external GPS is optional and intended for use when no other strong GPS signal is available for the Zipwake system, e.g. when the vessel has just one helm station with a shielding top (canopy) and lacks other accessible GPS sources. In this case, the external GPS antenna is a good solution. Its 5 m cable can be extended up to 15 m using Zipwake extension cables. It connects easily to the connector marked EXT GPS on the back of the control panel. The external GPS can be connected to any control panel installed in the system.

15.2 SPECIFICATIONS

Model	GPU
Connectors	M12 5-pin circular
Cable material	White PVC
Cable length	5 m (16 ft) extendable to max 15 m (49 ft)
Operating voltage	5 V DC \pm 5%
Power consumption	0.28 W, 55 mA (average)
Protocol	NMEA 0183 / RS232
NMEA sentences	RMC, VTG, GGA, GSA, GSV, GLL
Baud rate	38400
Update rate	5 Hz
Number of channels	20
Average time to first fix	Hot start 6 s, Warm start 38 s, Cold start 42 s
Operating temperature	-30° to +85°C (-22° to +185°F)
Storage temperature	-40° to +95°C (-40° to +203°F)
Waterproof rating	IP67
Compliance	CE, FCC
Weight	0.065 kg (0.14 lbs) without cable and connector
Mounting	Flush or pole

15.3 PIN OUT

1	+5 V
2	RX (to GPS)
3	GND
4	Not connected
5	TX (from GPS)

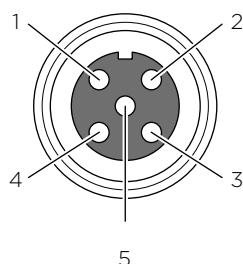

15.4 DIMENSIONS

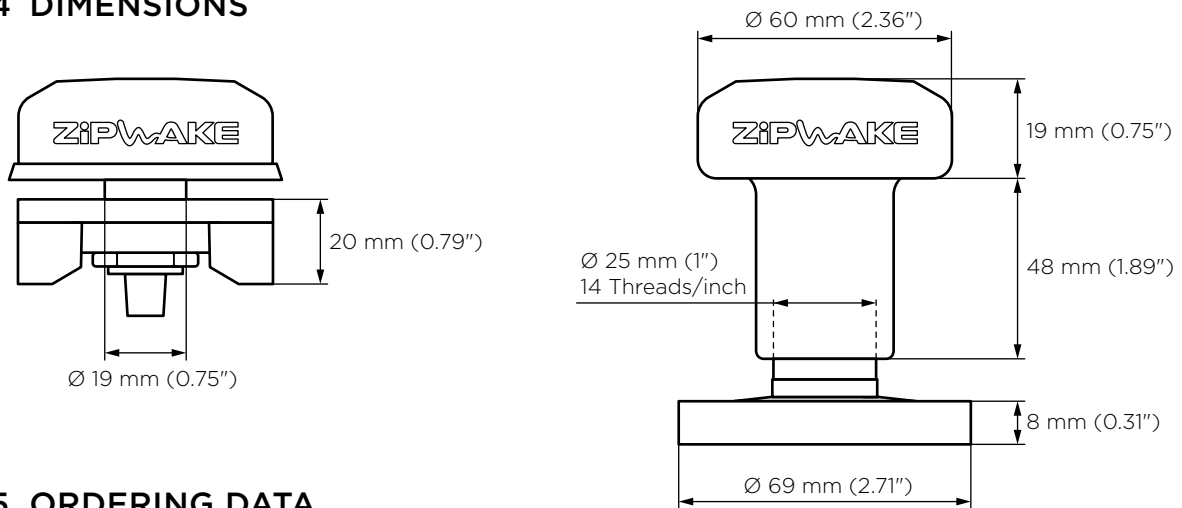

15.5 ORDERING DATA

Model	GPU
Part No.	2011240 with Cable 5 m and Mount Kit

- Available as an accessory
- Available as a spare part

16 UPGRADE KIT PRO

The Zipwake Upgrade Kit Pro is the perfect way to take an existing system to the next level. Simply replace the distribution unit, the servo units and update the software to go pro.

There are three kits available that all come with a distribution unit pro (DU PRO):

- **Upgrade Kit E Pro** with four servo units (SU-E PRO) for two dual-servo E interceptors.
- **Upgrade Kit 400E Pro** with two servo units (SU-400E PRO) for two 400 E interceptors.
- **Upgrade Kit 400E Pro Quad** with four servo units (SU-400E PRO) for four 400 E interceptors.



DU PRO



SU-E PRO



SU-400E PRO

For installations with more interceptors, additional servo unit(s) can be ordered separately as well as a distribution expansion unit (DU-EX PRO).

Refer to the distribution unit and servo unit chapters for more information about each part.

Software upgrade is available at zipwake.com.

16.1 ORDERING DATA

Model	UPGRADE KIT E PRO	UPGRADE KIT 400E PRO	UPGRADE KIT 400E PRO QUAD
Part No.	2022522	2022523	2022525
	Comes with 1 x DU PRO and 4 x SU-E PRO	Comes with 1 x DU PRO and 2 x SU-400E PRO	Comes with 1 x DU PRO and 4 x SU-400E PRO

- Available as an accessory

17 WIRING DIAGRAM

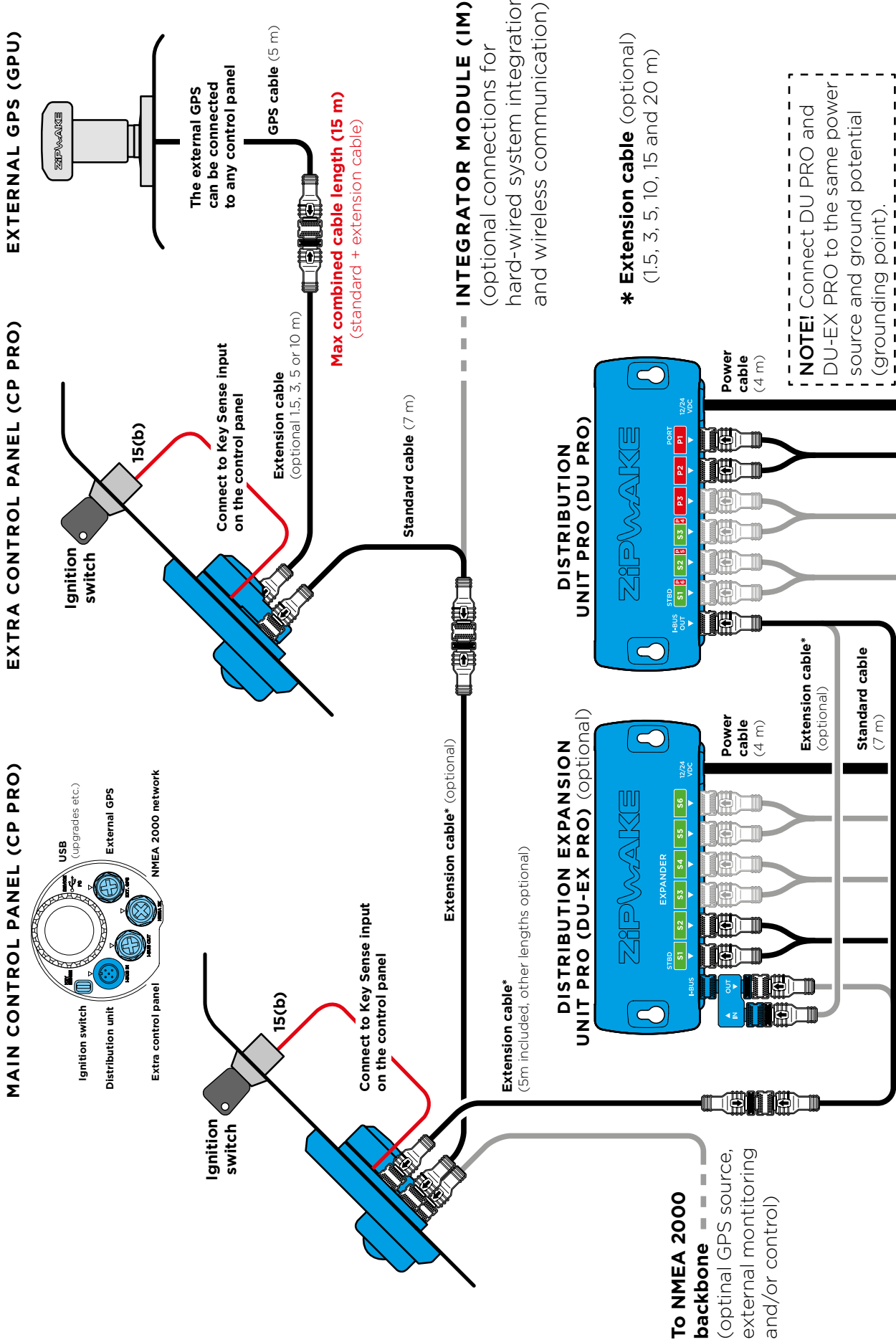

POWER SUPPLY (12-32 V DC)

15A melting type fuse **NOTE!** Do not use automatic thermal/magnetic fuse.

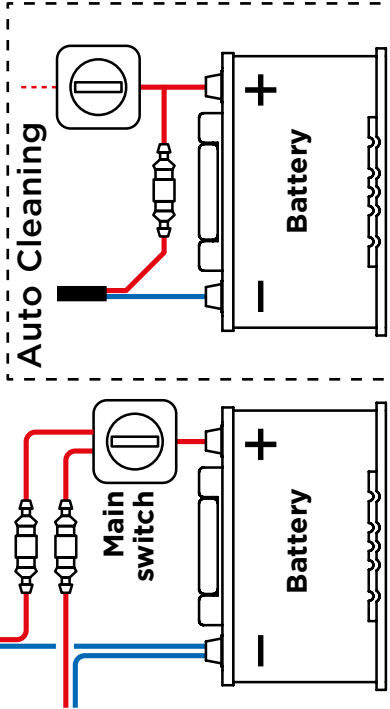

Auto Cleaning

NOTE! Connect power directly to the positive battery terminal if interceptor **Auto Cleaning** will be used. Refer to the Operator's Manual on how to turn on the interceptor **Auto Cleaning** function.

Up to six dual-servo pro interceptors or any mix with single-servo pro interceptors.

- Optional:**
Centerline mounted pro interceptor
- Single DU:**
- Dual-servo to P3 & S3
- Single-servo to P3
- Double DU:**
- Dual-servo to P5 & P6
- Single-servo to P6

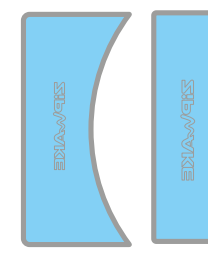

NOTE!
Transom inside view

NOTE! Only use Zipwake cables between Zipwake components.

Extension cable
(optional 1.5 or 3 m)

Max combined cable length (6 m)
(standard + extension cable)

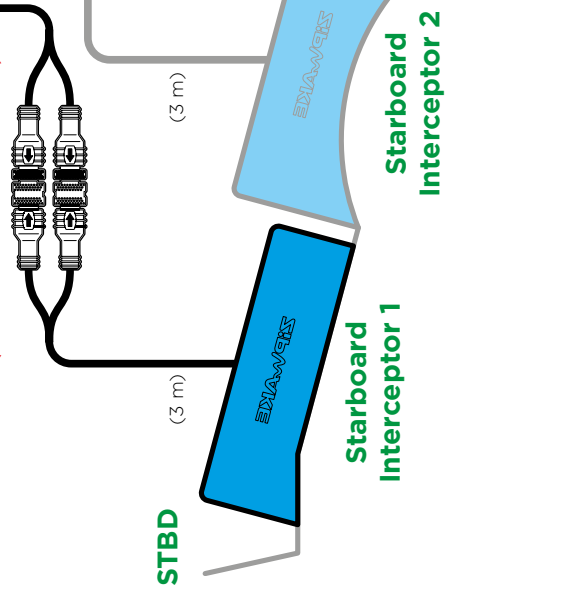

INTEGRATOR MODULE (IM) MOBILE DEVICE MULTIFUNCTION DISPLAY EXTERNAL GPS (GPU)

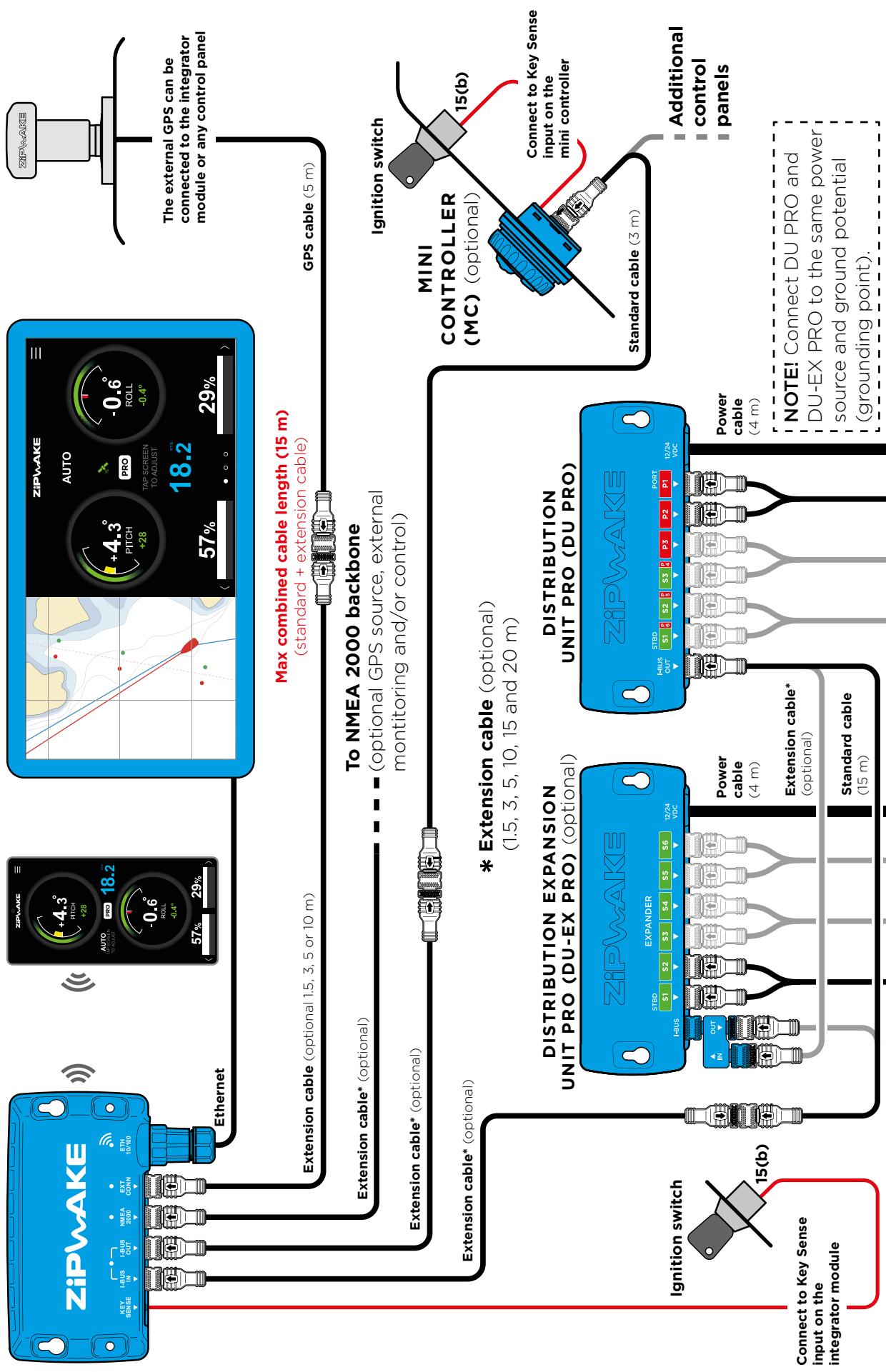

POWER SUPPLY (12-32 V DC)

15A melting type fuse

NOTE! Do not use automatic thermal/magnetic fuse.

Auto Cleaning

Main switch

Battery

Battery

NOTE! Connect power directly to the positive battery terminal if interceptor **Auto Cleaning** will be used. Refer to the Operator's Manual on how to turn on the interceptor **Auto Cleaning** function.

Up to six dual-servo pro interceptors or any mix with single-servo pro interceptors.

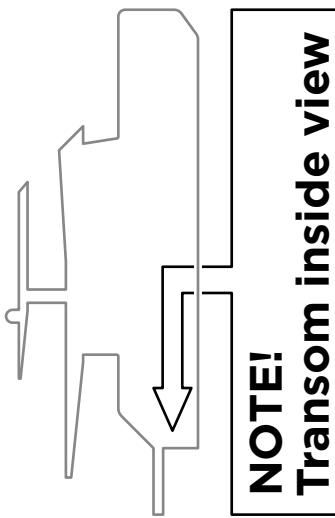

NOTE!
Transom inside view

NOTE! Only use Zipwake cables between Zipwake components.

Extension cable
(optional 1.5 or 3 m)

Max combined cable length (6 m)
(standard + extension cable)

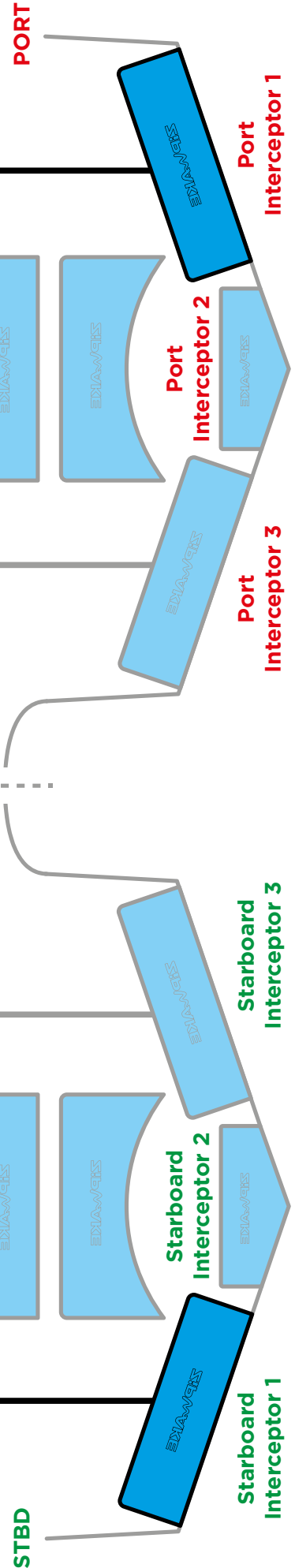
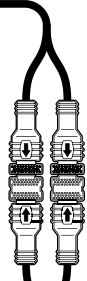



zipwake.com