

DYNAMIC TRIM CONTROL SYSTEM

FOR INTEGRATION

SERIES S | SERIES E

OPERATOR'S MANUAL

ZIPWAKE

TRIM CONTROL MADE EASY

Disclaimer

Zipwake disclaims any responsibility for loss of time, lifts, towing or transportation costs or any other indirect, incidental or consequential damage, injury, inconvenience or commercial loss when using this product. Zipwake will not assume liability in case of damage arising from improper use, improper installation or modification of our products or accidents involving them, or lost-profit claims by a third party.

Trademark notice

Zipwake is a registered trademark of Prezip Technology AB, Sweden. All other trademarks, trade names, or company names referred to herein are used for identification only and are the property of their respective owners.

Patent notice

This product is protected by patents, design patents, patents pending, or design patents pending.

Declaration of conformity

This product conforms to the following Electromagnetic Compatibility (EMC) regulations and standards for use in marine environments.

CE EN 60945

FCC CFR 47, Part 15, Subpart B

DNV Std No. 2.4

IACS E10

GL GL VI 7.2

Correct installation according to Zipwake documentation is required to ensure that EMC performance is not compromised.

The product follows ABYC recommended practices, E-11: AC and DC Electrical Systems on Boats and H-27: Seacocks, thru-hull fittings and drain plugs.

Zipwake Integrator Module is NMEA 2000® certified (software release 4.0 or higher). NMEA Network Message database version 3.000.

Documentation and technical accuracy

To the best of our knowledge, the information in this document was correct at the time it was produced. However, Zipwake cannot accept liability for any inaccuracies or omissions it may contain. In addition, our policy of continuous product improvement may change specifications without notice. As a result, Zipwake cannot accept liability for any differences between the product and this document.

Fair use statement

You may print a copy of this manual for your own use. You may not give or sell copies to third parties and not in any way exploit the manual commercially.

Product disposal



Dispose of this product in accordance with the WEEE Directive.

 The Waste Electrical and Electronic Equipment (WEEE)

The WEEE Directive does not apply to some Zipwake parts; however we support its policy and ask you to be aware of how to dispose of this product.

Product Registration

Register your product online at zipwake.com/register to allow notifications of news and available software updates etc.

DISCLAIMER

ALL PRODUCT SPECIFICATIONS AND DATA ARE SUBJECT TO CHANGE WITHOUT NOTICE TO IMPROVE RELIABILITY, FUNCTION OR DESIGN OR OTHERWISE.

Zipwake, its affiliates, agents, and employees, and all persons acting on its or their behalf (collectively, "Zipwake"), disclaim any and all liability for any errors, inaccuracies or incompleteness contained in any datasheet or in any other disclosure relating to any product.

TABLE OF CONTENTS

1	IMPORTANT INFORMATION	4
1.1	READING THE OPERATOR'S MANUAL	
1.2	GENERAL SAFETY INSTRUCTIONS	
1.3	SPECIAL OPERATING NOTES	
2	SYSTEM OVERVIEW	5
3	INSTALLATION	6
3.1	CONNECTING AN EXTERNAL GPS	
3.2	IGNITION SWITCH INSTALLATION	
3.3	CONNECT TO DEVICES	
4	INTEGRATOR MODULE OVERVIEW	7
4.1	INTEGRATOR MODULE INDICATORS	
4.3	MAIN DISPLAY OVERVIEW	
5	INITIAL START	9
5.1	SETTING UP THE SYSTEM	
6	AFTER LAUNCH	12
6.1	SELECT GPS SOURCE	
6.2	RESET THE PITCH AND ROLL ANGLES	
6.3	SET/VERIFY INTEGRATOR MODULE ORIENTATION ANGLE	
7	MANUAL ATTITUDE CONTROL	14
7.1	MANUAL PITCH AND ROLL	
7.2	STEERING MODE	
8	AUTO / AUTO PITCH CONTROL	15
8.1	AUTOMATIC PITCH	
8.2	AUTOMATIC ROLL	
8.3	ACTIVATE AUTO / AUTO PITCH	
8.4	PITCH OFFSET	
8.5	EDIT THE AUTO PITCH CONTROL CURVE	
8.6	AUTO ROLL SPEED RANGE	
8.7	AUTO ROLL LEVEL	
9	INTERCEPTOR SETUP	19
9.1	MANUAL CONTROL RATE	
9.2	AUTO CLEANING	
9.3	INTERCEPTOR CONFIGURATION	
9.4	INTERCEPTOR CHECK	
10	SWITCHING THE SYSTEM ON	22
11	SWITCHING THE SYSTEM OFF	22
11.1	TURN OFF	
11.2	TURN OFF - OPTIONAL MINI CONTROLLER	
11.3	TURN OFF - OPTIONAL CONTROL PANEL	
12	ADVANCED SETUP	23
12.1	TOUCH LOCK	
12.2	SOFTWARE UPDATE - Mobile DEVICES	
12.3	SOFTWARE UPDATE - OPTIONAL CONTROL PANEL	
12.4	RESTART THE SYSTEM	
12.5	FACTORY RESET	
12.6	IMPORT/EXPORT DATA	
13	NMEA 2000	25
14	TROUBLESHOOTING	26
14.1	SYSTEM ERROR INFORMATION	
14.2	ERROR CORRECTIVE ACTIONS	
14.3	OTHER ERRORS	
15	MAINTENANCE	28
15.1	LAUNCH	
15.2	HAUL-OUT	
16	OPTIONAL MINI CONTROLLER	29

1 IMPORTANT INFORMATION

1.1 READING THE OPERATOR'S MANUAL

Make sure that you read and understand this Operator's Manual before using the Dynamic Trim Control System. If you have trouble understanding any part of the manual, please contact your retailer for further information.

⚠ IMPORTANT Information presented as IMPORTANT may lead to system or property failure or damage if it is disregarded.

⚠ WARNING Information presented as a WARNING may lead to personal injury if it is disregarded.

NOTE!

Information presented as a NOTE! is important information about the Trim Control System's operation and features.

1.2 GENERAL SAFETY INSTRUCTIONS

The Trim Control System is an accessory that delivers a more comfortable boat ride, better performance and improved fuel consumption. Keep in mind that it under no circumstances takes away the responsibility from the helmsman to maneuver the boat in a safe way.

Take your time to get familiar with the system and its functions in calm waters and get used to how it will affect your boat's handling before using it under normal conditions.

⚠ WARNING The Trim Control System may affect your boat's capacity to stay on course. Always pay close attention to steering the boat.

⚠ WARNING Never try to force the interceptor blades by hand. Watch out for sharp edges when close to the interceptors. Turn off the system when the boat is docked, at anchor or hauled out of the water.



1.3 SPECIAL OPERATING NOTES

⚠ IMPORTANT The Dynamic Trim Control System should be the main system controlling your boat's running trim. If the boat has an outboard engine or a sterndrive, their respective trim (propeller shaft inclination) should be set to zero, except possibly at high speeds, or if automatic control is added when necessary in addition to the basic trim provided by the interceptors.

2 SYSTEM OVERVIEW

The Dynamic Trim Control System for integration incorporates an integrator module and a state-of-the-art family of durable, fast-acting interceptors perfectly engineered for boats up to 30 m (100 ft). The integrator module provides connections for wired system integration and wireless communication. All Zipwake functions are integrated and controlled from multifunction display(s) (MFD) or other external/mobile device(s). The user-friendly interface provides the helmsman with intuitive and precise control of running trim, heel or heading. The system is fully automatic and significantly enhances the boat's performance, fuel economy, comfort and safety.

KEY FEATURES

INTEGRATED MONITORING AND SYSTEM CONTROL

The system is monitored and/or controlled from MFD(s), plotter(s) or other external/mobile device(s) etc. The system can also be controlled by optional Zipwake mini controller(s) or Zipwake Control Panel(s) (refer to the Series S or E Operator's manual). The system is NMEA 2000® certified (chapter 13).

AUTO PITCH CONTROL

The system will automatically adjust the trim or pitch angle of your boat, minimizing wave resistance for best performance and comfort at all speeds (chapter 8).

AUTO ROLL CONTROL - AUTO

The system will automatically eliminate uncomfortable and dangerous boat roll in addition to controlling the trim or pitch angle. The system constantly works to keep the boat level or to make balanced (banked) turns (chapter 8).

MANUAL ATTITUDE CONTROL

When in manual mode, the boat's running attitude (chapter 7) can be controlled from the interface by using the manual control buttons to adjust the trim and the list angle.

SYSTEM OVERVIEW

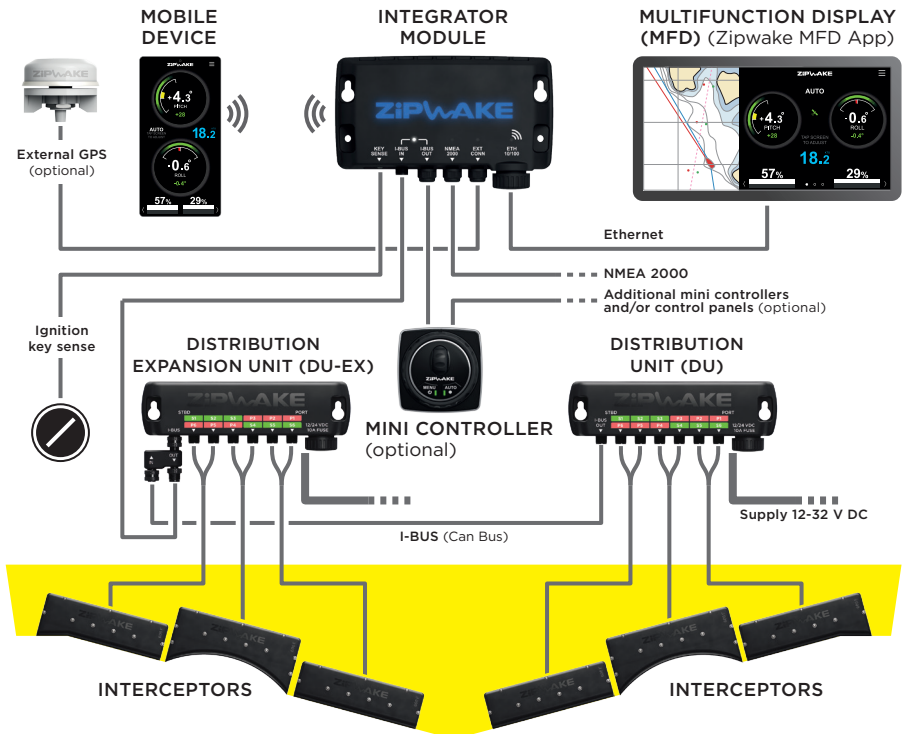

3 INSTALLATION

Follow the steps in the Zipwake Installation Guide (Series S or E) for mounting and connecting interceptors, the distribution unit(s), integrator module, control panel(s) and extra GPS on your boat.

3.1 CONNECTING AN EXTERNAL GPS

⚠ IMPORTANT The system's automatic control functions remain off/turn off when no GPS speed signal is available.

The integrator module requires at least one external GPS signal via NMEA 2000, a Zipwake external GPS or a Zipwake control panel. The system will automatically use the source with the best reception. Refer to the wiring diagram in the Installation Guide.



3.2 IGNITION SWITCH INSTALLATION

Connect the boat's ignition switch to the Key Sense input (A) on the integrator module so that the system is automatically turned on/off when the ignition (engine) is turned on/off. Refer to the Installation Guide wiring diagram.



NOTE!

If a Zipwake control panel(s) is installed, connect the boat's ignition switch to the Key Sense input on the back of the control panel in the same way as on the integrator module.

3.3 CONNECT TO DEVICES

MULTIFUNCTION DISPLAY (MFD)

The Zipwake application automatically appears on a connected (compatible) MFD. Refer to the MFD manufacturer or manual for detailed information on compatible models and how to launch integration applications, such as the Zipwake application on your MFD model. At first start-up, follow the steps (chapter 5) on the MFD to complete the system installation.



MOBILE DEVICE

Scan the QR-code on the integrator module label **1** to connect to the Wi-Fi network (also available from the System Information page when the Zipwake application is installed). Scan the QR-code from integrator module label **2** to launch the Zipwake application (APP) and add it to the device start screen for future use. At first start-up, follow the steps (chapter 5) in the application to complete the system installation.



NOTE!

Follow all the steps of the initial start (chapter 5) and confirm that the pitch and roll angles are reset and the orientation angle is entered correctly.

4 INTEGRATOR MODULE OVERVIEW

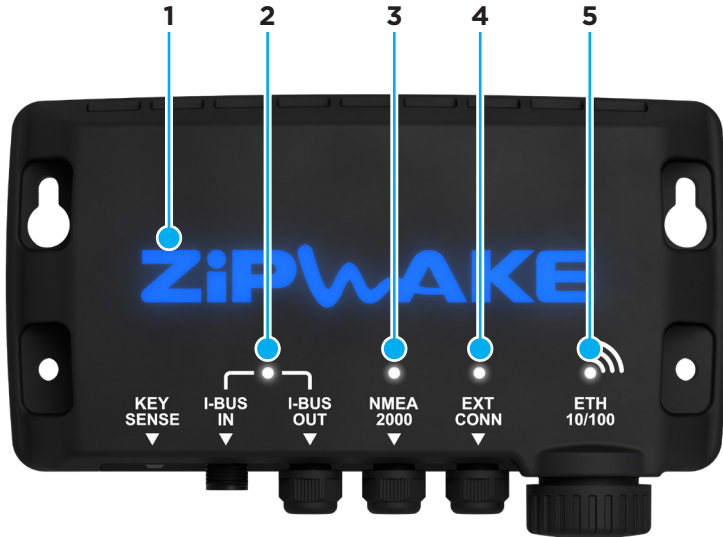

4.1 INTEGRATOR MODULE INDICATORS

- 1 Zipwake logo**
RGBW backlit logotype with system status indication.
(OFF - turned off, white - initializing, blue - OK, green - updating, red - system error)
- 2 I-BUS IN**
Status indicator for the I-BUS communication.
(OFF - no communication, white - OK, red - communication error)
- 3 NMEA 2000**
Status indicator for the NMEA 2000 communication.
(OFF - no communication, white - OK, red - communication error)
- 4 EXT CONN**
Status indication of the external connection.
(OFF - not connected, white - OK, red - error)
- 5 ETH 10/100/Wi-Fi symbol**
Status indicator for the ethernet and/or the Wi-Fi connection.
(OFF - not connected, white - ETH or ETH+WiFi, yellow - Wi-Fi, red - error.)

4.3 MAIN DISPLAY OVERVIEW

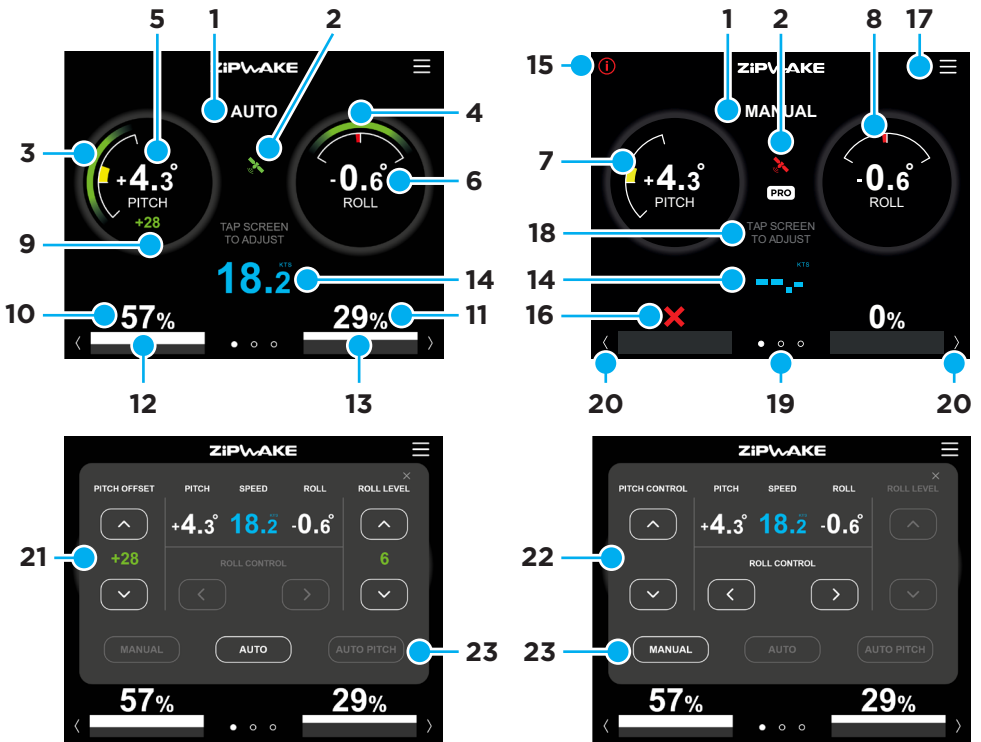

- 1 **Mode:** Indicates current mode - AUTO, AUTO PITCH or MANUAL
- 2 **GPS status:** Green/No symbol - GPS fix OK | Yellow - No GPS fix | Red - No GPS connection
- 3 **Green arc:** Indicate that Auto Pitch Control is activated.
No green arc: Indicates manual pitch control - Auto Pitch Control turned off.
- 4 **Green arc:** Indicate that Auto Roll Control is activated.
No green arc: Indicates manual roll control - Auto Roll Control turned off.
- 5 **Pitch Angle:** Pitch angle indicator in degrees.
- 6 **Roll Angle:** Roll angle indicator in degrees.
- 7 **Pitch Indicator:** Visualizes the current pitch angle of the boat.
- 8 **Roll Indicator:** Visualizes the current roll angle of the boat.
- 9 **Pitch Offset:** Indicates manual pitch offset in Auto mode.
- 10 **Port Interceptor Position:** Indicates port Interceptor(s) extension in percent.
- 11 **Starboard Interceptor Position:** Indicates starboard Interceptor(s) extension in percent.
- 12 **Port Interceptor Feedback:** Visualizes the current port Interceptor extension.
- 13 **Starboard Interceptor Feedback:** Visualizes the current starboard Interceptor extension.
- 14 **Boat Speed:** Current speed over ground. No GPS signal - No speed numbers.
- 15 **Error Information:** Indicates a system error - check the System Information menu.
- 16 **Interceptor Error:** Indicates an Interceptor error - check the System Information menu.
- 17 **System Menu:** Tap to open menu.
- 18 **Controls:** Tap screen to open control window
- 19 **Page indicator:** Current view highlighted - Swipe to change view.
- 20 **Page arrows:** Tap to change view.
- 21 **Control window Auto mode:** Tap/hold arrows to adjust auto control functions.
- 22 **Control window Manual mode:** Tap/hold arrows to control pitch and roll.
- 23 **Mode buttons:** Tap buttons to change mode.

5 INITIAL START

5.1 SETTING UP THE SYSTEM

NOTE! All selections made during Initial Start can be edited later from the System Menu.

1. Initially, the ZIPWAKE logo on the integrator module pulsates, and becomes a steady blue light when fully powered up.
Once powered up and the Zipwake application is launched (chapter 3.3) on a connected MFD or mobile device, read the ATTENTION text and press OK or wait (7 sec) for the next step.



2. Select Language and tap NEXT.

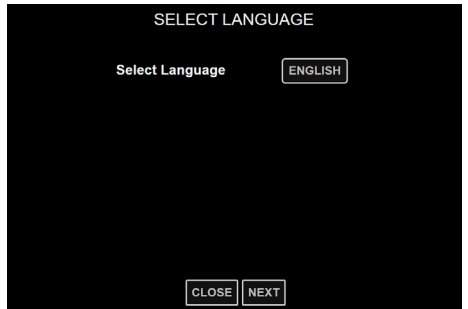

3. Select Units and tap NEXT.
Metric: Kilograms, meters
Imperial: Pounds, feet

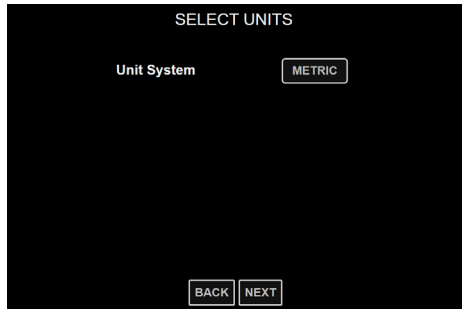

4. Enter boat length, beam, weight, hull type (mono or catamaran) and tap NEXT.

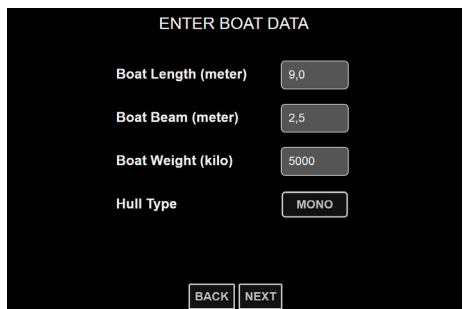

NOTE!

The system's automatic control functions need correct boat data to work properly. Hull length, max chine beam, and half load displacement are good choices.

- Select the distribution unit installation(s) (DU installation) that represent the actual installation (Single or DU-EX Port/Starboard side).
- Verify that the Interceptor Configuration represents the actual installation and tap NEXT.

Single Distribution Unit

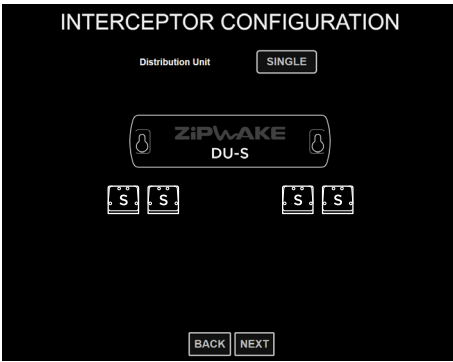

Double Distribution Units

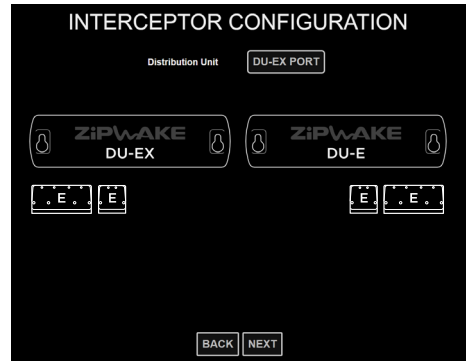

NOTE!

Refer to Interceptor Configuration (chapter 9.3) for more information.

- Make sure the integrator module orientation angle (mounting angle relative to the boat's forward direction) is set as accurately as possible according to the figures below, then tap NEXT.

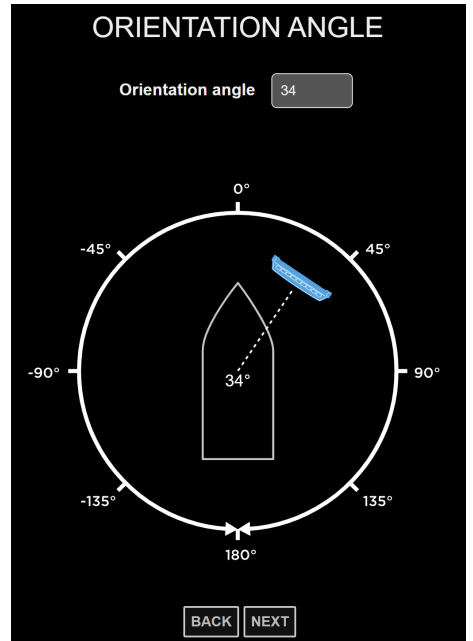
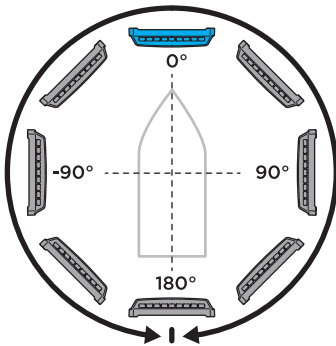

NOTE!

If the orientation angle is difficult to measure or estimate, use a compass or a mobile device compass application to determine the integrator module's angle relative the boats forward direction within $\pm 5^\circ$.

8. Tap START to run the Interceptor Check.

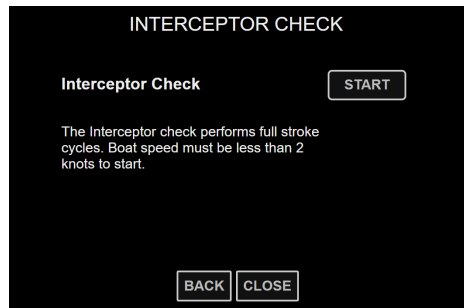

9. Tap the arrows (A) to toggle different positioned interceptors, i.e. from Port interceptor 1 to Starboard interceptor 1. Tap CLOSE when the Interceptor Check is completed.

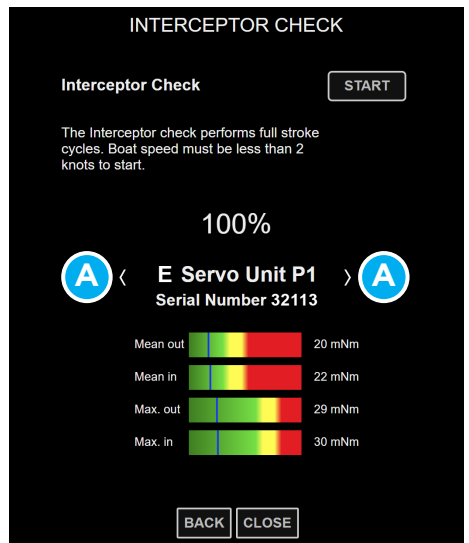

NOTE!

Interceptor Check will not start if no interceptor configuration has been saved to the system (chapter 9.3).

The check repeats a 5 stroke sequence, where each interceptor blade is extended, one by one, from port to starboard and then retracted in the same order. Visually confirm that the interceptors move accordingly during the check. This confirms that the interceptors are correctly connected to the distribution unit(s).

For easy servo torque level assessment, the numerical values are depicted in green-to-red bar graphs, where green is acceptable and red is too high.

Refer to Interceptor Check (chapter 9.4) for more information.

⚠ IMPORTANT All readings must be green!
Corrective actions are always necessary when excessive torque levels are observed. Verify the flatness of the transom, excess use of sealant behind the interceptor and/or excess antifouling between the blades and adjust if needed. Check for blade damage and marine growth at regular intervals.

Always use the controls to move the interceptor blades.
Never try to force the interceptor blades by hand.

10. The system now resets the pitch and roll angles and calculates the Auto Pitch Control Curve, which tells the system how much the interceptors will be extended at each speed when Auto Pitch Control (chapter 8) is activated. Tap NEXT or wait for the main display to appear.

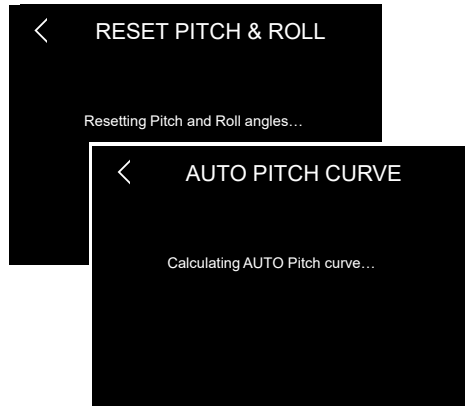

NOTE!

You can always start from the beginning by performing a Factory Reset (chapter 12.5).

6 AFTER LAUNCH

The Initial Start procedure is often done on shore in conjunction with system installation. We also recommend confirming the following when the boat is launched:

6.1 SELECT GPS SOURCE

1. Tap  to open the System Menu.
2. Tap Select GPS Source.

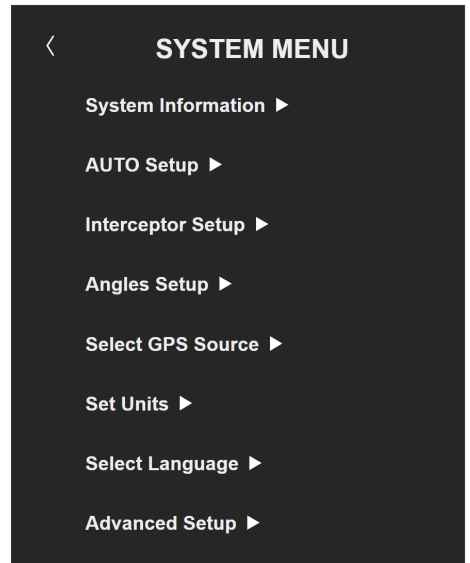

3. GPS Source is set to AUTO by default. The system will automatically select the GPS with the best reception and show it in the menu header.
4. GPS Status should be GOOD or EXCELLENT. If not, see troubleshooting (chapter 14).

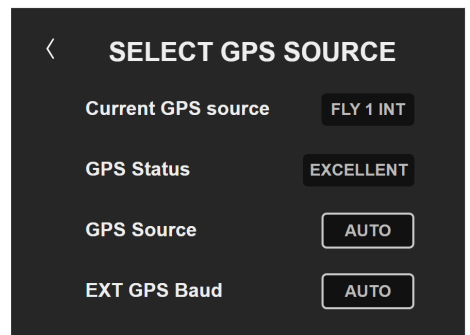

6.2 RESET THE PITCH AND ROLL ANGLES

⚠ IMPORTANT During Initial Start, the pitch and roll angle indicators are reset. When launched, level the boat in calm waters at a standstill and perform a reset manually for the system's automatic control functions to work properly.

1. Tap  to open the System Menu.
2. Tap Angles Setup.
3. Tap RESET to set the pitch/roll angle to zero. Tap YES in the pop-up window to confirm.

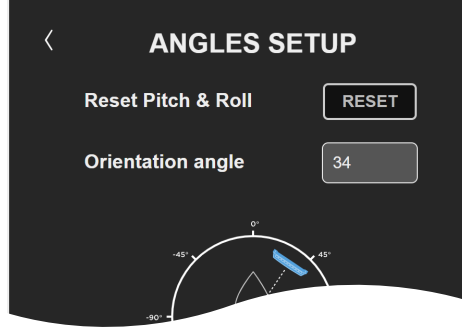

NOTE!

Both the pitch and roll angles should now read close to 0.0°.

6.3 SET/VERIFY INTEGRATOR MODULE ORIENTATION ANGLE

1. Make sure the integrator module orientation angle (mounting angle relative the boat's forward direction) is set within $\pm 5^\circ$ according to the figures below.
1. Tap  to open the System Menu.
2. Tap Angles Setup.
3. Set/verify Orientation angle.

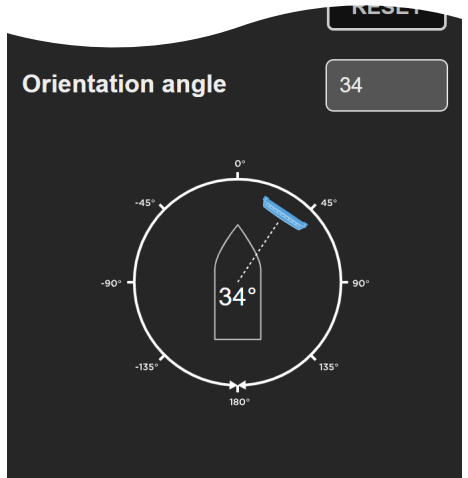
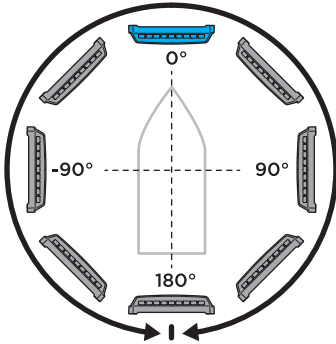

NOTE!

If the orientation angle is difficult to measure or estimate, use a compass or a mobile device compass app to determine the integrator module's angle relative the boat's forward direction within $\pm 5^\circ$.

7 MANUAL ATTITUDE CONTROL

7.1 MANUAL PITCH AND ROLL

With the system in Manual mode, the boat's running attitude can be manually controlled using the control buttons in the Zipwake application. The up/down buttons control the trim or pitch angle, while the left/right buttons control the list or roll angle.

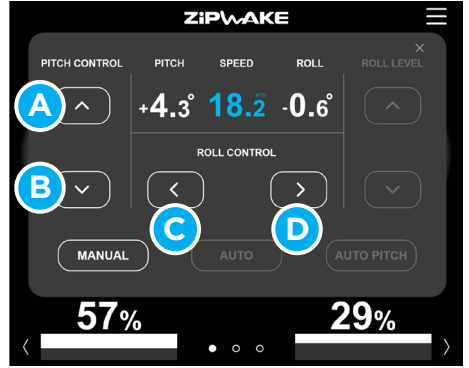

Bow down

Tap/hold the bow down icon (A)

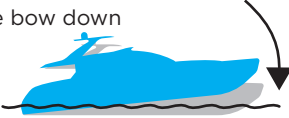

Correcting starboard list

Tap/hold the roll icon (C)



Bow up

Tap/hold the bow up icon (B)

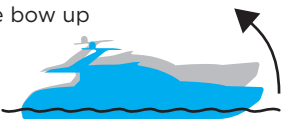

Correcting port list

Tap/hold the roll icon (D)



7.2 STEERING MODE

With Steering mode activated the boat's heading or yaw angle can be manually controlled from the Zipwake application.

⚠ IMPORTANT Steering mode should only be used to make sensible course corrections when running in relatively calm waters. Steering mode remains off/turns off if Auto Roll Control (chapter 8) is activated.

1. Tap the arrows (A) or swipe to the steering mode view.
2. Tap ON (B) to activate steering mode.
3. Tap the arrows (C) to steer. Course Over Ground (COG) is displayed in yellow numbers (D).

NOTE!

If steering is deactivated for all interceptor pairs (chapter 9.3.2) the steering mode page will not be visible.

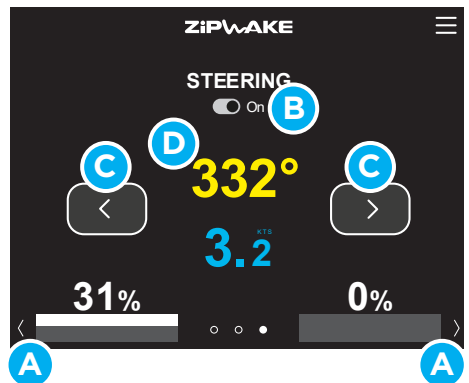

8 AUTO / AUTO PITCH CONTROL

8.1 AUTOMATIC PITCH

With Auto or Auto Pitch Control activated, the system will automatically adjust the running trim of your boat, minimizing wave resistance for best performance and comfort at all speeds. The Auto Pitch Control Curve tells the system how much the interceptors will be extended at each speed, thereby adjusting the boat's pitch angle as a function of speed.

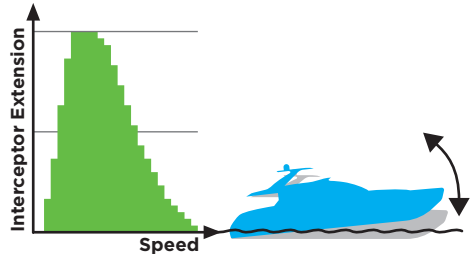

8.2 AUTOMATIC ROLL

With Auto Roll Control activated (AUTO), the system will automatically eliminate uncomfortable and dangerous boat roll. The system constantly works to keep the boat level or to make balanced (banked) turns. For boats that tend to heel too much inward in turns, the system will help the boat make sharper turns.

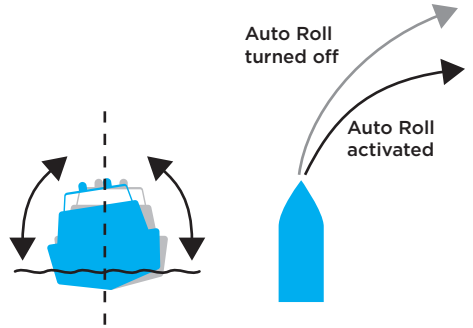

⚠ IMPORTANT The system's automatic control functions remain off/turn off when no GPS speed signal is available or in the event of other system failure(s). A flashing error message is then shown at the bottom of the main display.

Auto Roll Control is only active if boat speed is within the Auto Roll speed range (chapter 8.6). The system's automatic control functions remain off / turned off when no GPS speed signal is available.

8.3 ACTIVATE AUTO / AUTO PITCH

1. To activate Auto mode, tap the screen to open the control window and tap AUTO (A). Green arcs will appear at the pitch (B) and roll (C) gauges.
2. To activate Auto Pitch Control only, tap AUTO PITCH (D); it will turn white and the green arc at the roll (C) gauge will disappear.
3. Tap AUTO (A) to activate Auto Roll Control again.
4. Tap MANUAL (E) to return to Manual mode.

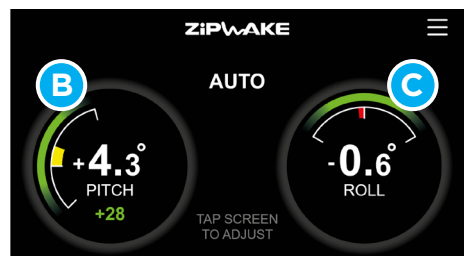
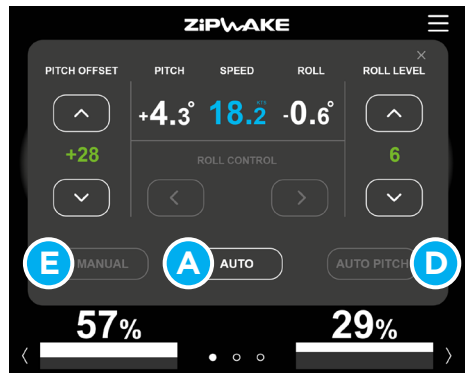

8.4 PITCH OFFSET

The running trim can be altered (pitch offset) to adjust the boat's trim at certain loads, speeds, and/or sea conditions.

1. To trim the bow down, tap/hold arrow up (A) to increase pitch offset.
2. To trim the bow up, tap/hold arrow down (B) to decrease pitch offset.

The applied offset is shown in green numbers (C).

NOTE!

The pitch offset stays the same until it is altered again. To remove the offset adjust back to zero (no green numbers). The offset is also reset when exiting auto mode and at system restart.

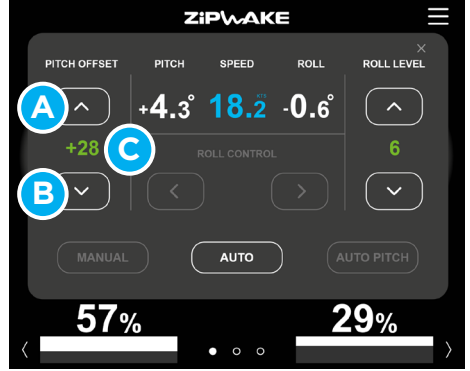

⚠ IMPORTANT Avoid trimming down the bow excessively as this can result in bow steering and course instability.

If the adjusted pitch offset resulted in a better running trim, you can save it by holding the pitch offset value indication (C) until it disappears. The Target Pitch angle and Auto Pitch curve is adjusted accordingly. The Auto Pitch Curve is adjusted locally according to the boat's current speed.

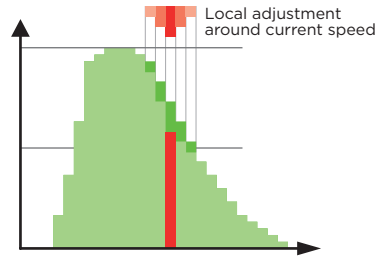

NOTE!

Saving a preferred trim setting in this manner, at a few different boat speeds, is a very quick way to build the optimum pitch curve for your boat with its specific load. Details of the curve can be viewed and adjusted from the menu page (chapter 8.5).

8.5 EDIT THE AUTO PITCH CONTROL CURVE

The Auto Pitch Control Curve tells the system how much the interceptors should be extended at each speed, thereby adjusting the boat's pitch angle as a function of speed. When starting the system the first time (chapter 5), a default curve is calculated based on your boat data (length, beam, weight). The Auto Pitch Control Curve can be viewed and fine-tuned from the menu page.

1. Tap  to open the System Menu.
2. Tap AUTO Setup.
3. Tap OPEN or on the pitch curve to enable pitch curve adjustment.

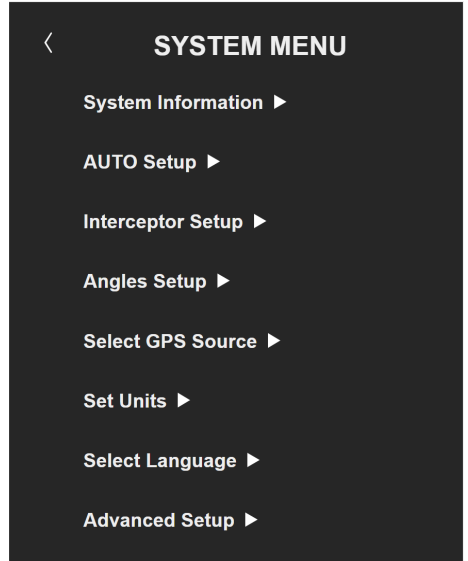

4. Adjust the pitch curve bars (A) by touch and drag or use the buttons (B) to adjust the extension for a desired speed.
5. Repeat step 4 to adjust more than one setting.
6. Tap SAVE to update the curve.

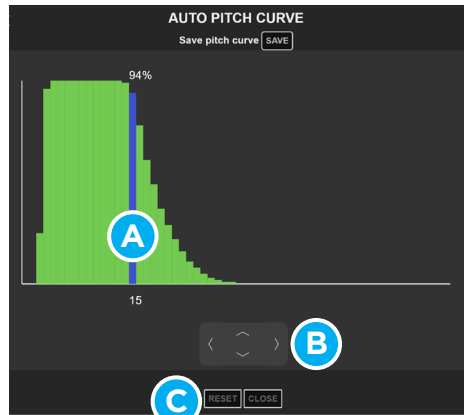

NOTE!

Tap RESET (C) to reset the Auto Pitch Control Curve to the default settings for the current boat data.

8.6 AUTO ROLL SPEED RANGE

The Auto Roll Control is active within a speed range that is calculated based on the entered boat data. The lower and upper limits can be adjusted from their default values.

1. Tap  to open the System Menu.
2. Tap AUTO Setup.
3. Tap AUTO Roll Setup.
4. Adjust the Lower/Upper Limit.

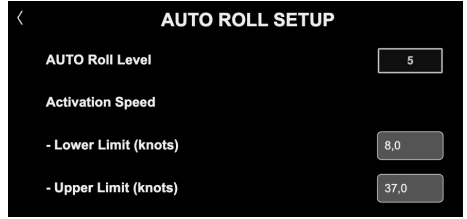

NOTE!

Once speed exceeds the upper limit, AUTO roll remains inactive until speed drops below the upper limit by 6 knots while holding a steady heading.

8.7 AUTO ROLL LEVEL

1. Tap/hold arrow up (A) to increase roll level.
2. Tap/hold arrow down (B) to decrease roll level.

NOTE!

Roll Level 5 equals normal (default) responsiveness. Try different Levels until you are satisfied. The new Roll Level (C) is saved until you select a new level.

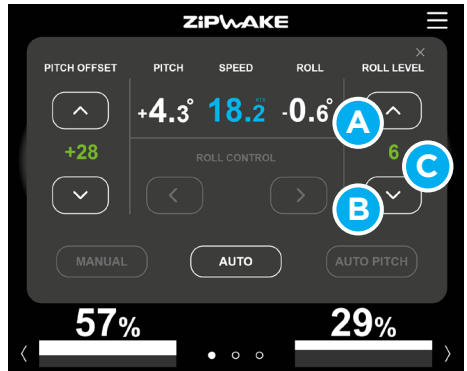

9 INTERCEPTOR SETUP

9.1 MANUAL CONTROL RATE

With the system in Manual mode, the relationship between the turning rate of the control wheels and the interceptors' actuation speed can be adjusted from low to high. A high control rate provides fast actuation for more aggressive manual piloting, whereas a low setting is the default and sufficiently fast for most helmsmen.

1. Tap  to open the System Menu.
2. Tap Interceptor Setup.
3. Select the desired Manual Control Rate.

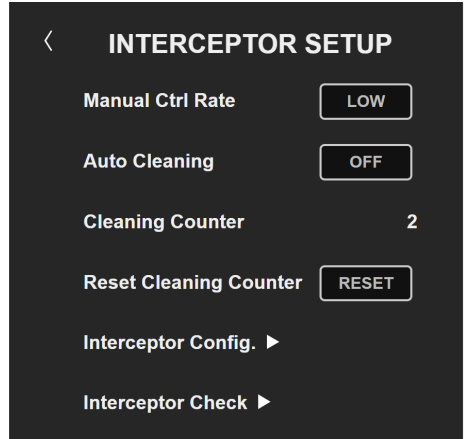

9.2 AUTO CLEANING

With Auto Cleaning enabled the system automatically carries out 3 consecutive cleaning cycles (blade moves in-out-in) with a periodicity selectable from 24 hours to 4 weeks. Moving the interceptor blade frequently in-and-out is an effective way to prevent fouling on the insides of the interceptors when boats stay in the water for long periods.

Refer to the Installation Guide's wiring diagram for information about connecting system power if Auto Cleaning is to be used.

1. Tap  to open the System Menu.
2. Tap Interceptor Setup.
3. Select the desired Auto Cleaning interval.

Reset the cleaning counter:

1. Tap  to open the System Menu.
2. Tap Interceptor Setup.
3. Tap RESET to zero the Cleaning Counter. Tap YES in the pop-up window to confirm.

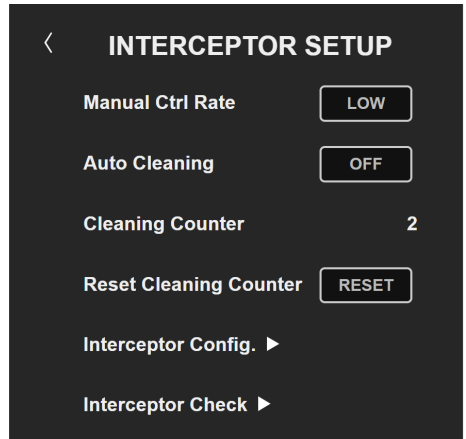

NOTE!

Disable Auto Cleaning or disconnect power to the system when the boat is hauled out of the water.

9.3 INTERCEPTOR CONFIGURATION

Details about the current system installation including distribution unit(s) and interceptor configuration are managed and visualized from the Interceptor Configuration menu page.

ENTER THE INTERCEPTOR CONFIGURATION MAIN PAGE

1. Tap  to open the System Menu.
2. Tap Interceptor Setup
3. Tap Interceptor Configuration.



9.3.1 DISTRIBUTION UNIT(S)

1. Verify/Select the DU installation that represents the actual system installation.
2. Select SINGLE if the system installation only includes a Distribution Unit for Series S or E (DU-S or DU-E).
3. If the system installation includes a Distribution Expansion Unit (DU-EX) select the option that specifies the mounting side that represents the actual installation (DU-EX PORT SIDE or DU-EX STBD SIDE).

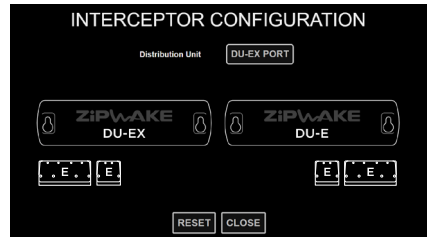
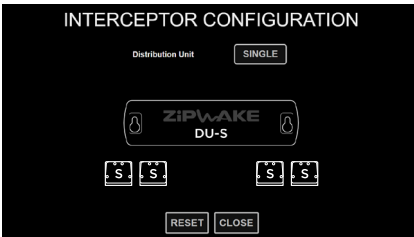

9.3.2 CUSTOM ALLOCATION OF CONTROL FORCES

The system allows custom allocation of control forces by setting pitch, roll and yaw control as active or inactive for each pair of port and starboard interceptors. A pair's function may also be switched e.g. to mitigate roll-induced steering forces from another interceptor pair or pairs.

1. Tap the Interceptor illustrations to select an interceptor pair.
2. Set the desired interceptor function for each pair.

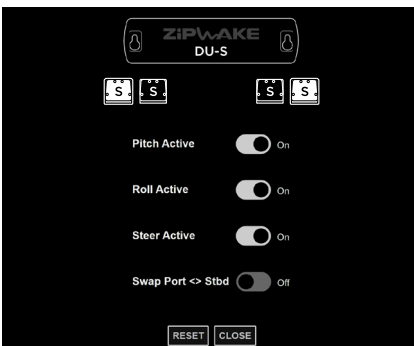

NOTE!

In systems with multiple interceptor pairs, the first pair will always be active in pitch and roll. A center-mounted interceptor only controls pitch. Refer to the Installation Guide for information about connecting a center-mounted interceptor to the distribution unit.

Tap RESET to reset the configuration saved to the system and let the system re-evaluate the connected interceptor configuration.

9.4 INTERCEPTOR CHECK

Carry out an Interceptor Check to verify function immediately after installation and before launching the boat. Repeat this before every launch.

When launched, carry out an Interceptor Check at regular intervals to monitor the status of each interceptor.

NOTE!

Interceptor Check will not start if no interceptor configuration has been saved to the system (chapter 9.3).

The check repeats a 5 stroke sequence, where each interceptor blade is extended, one by one, from port to starboard and then retracted in the same order. Visually confirm that the interceptors move accordingly during the check. This confirms that the interceptors are correctly connected to the distribution unit(s).

For easy servo torque level assessment, the numerical values are depicted in green-to-red bar graphs, where green is acceptable and red is too high.

1. Tap  to open the System Menu.
2. Tap Interceptor Setup.
3. Tap Interceptor Check to perform the test cycle.
4. Tap START to run the Interceptor Check.

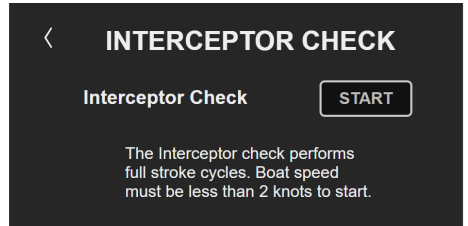

5. Tap the arrows (A) to toggle different positioned interceptors, i.e. from Port interceptor 1 to Starboard interceptor 1.

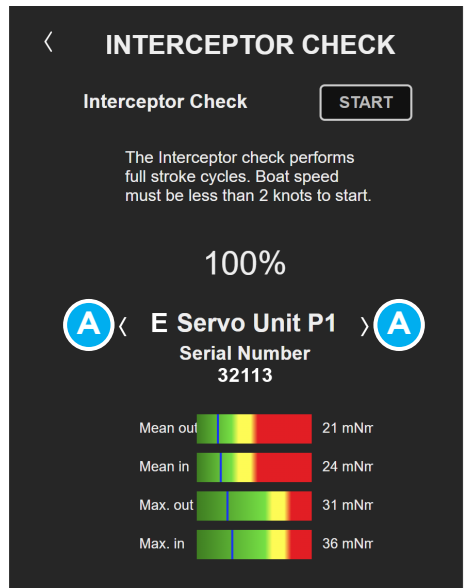

IMPORTANT All readings must be green!

Corrective actions are always necessary when excessive torque levels are observed. Verify the flatness of the transom, excess use of sealant behind the interceptor and/or excess antifouling between the blades and adjust if needed. Check for blade damage and marine growth at regular intervals.

Always use the controls to move the interceptor blades. Never try to force the interceptor blades by hand.

10 SWITCHING THE SYSTEM ON

The system is switched on by any of the following events:

1. Powering up the integrator module.
2. By the boat's ignition switch when connecting it to the integrator module's Key Sense input.
3. When the NMEA 2000 network is powered up (if the integrator module is connected to NMEA 2000).
4. When an optional mini controller or a control panel is turned on using its power button.

NOTE!

Items 2 - 4 only apply if the integrator module remains connected to a power source when turned off.



11 SWITCHING THE SYSTEM OFF

NOTE!

The system also automatically turns off after 12 hours of standstill (no GPS speed).

With Auto Cleaning enabled (chapter 9.2), the system will automatically wake up periodically and carry out 3 consecutive cleaning cycles when the system is turned off.

11.1 TURN OFF

The system is turned off when the ignition switch (engine) is turned off.

11.2 TURN OFF - OPTIONAL MINI CONTROLLER

Press and hold the mini controller's POWER button until the system turns off.

11.3 TURN OFF - OPTIONAL CONTROL PANEL

If optional control panel(s) are installed, they can either turn off the system or only the display concerned.

1. Press and hold the control panel's POWER button until the System Turn-Off menu appears.
2. A: Select Turn Off Display and press SELECT to turn off the display. Press the POWER button to reactivate the display.
or
B: Select Turn Off System and press SELECT to turn off the system. The system is turned off and the interceptors are automatically retracted.

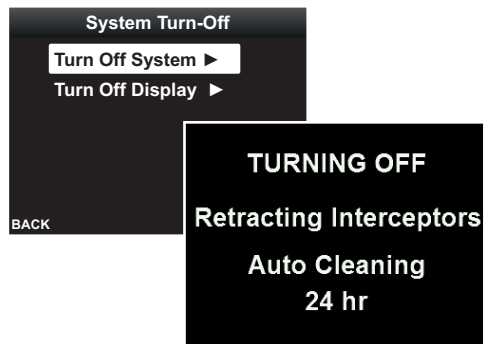

12 ADVANCED SETUP

12.1 TOUCH LOCK

Touch Lock is disabled by default allowing adjustments to the system from the connected device (e.g MFD or mobile device). Enable Touch Lock to prevent undesired adjustments from the connected device.

1. Tap ☰ to open the System Menu.
2. Tap Advanced Setup.
3. Tap the Touch Lock toggle slider to enable/disable the Touch Lock.

NOTE!

The Touch Lock setting only applies locally to the current device.

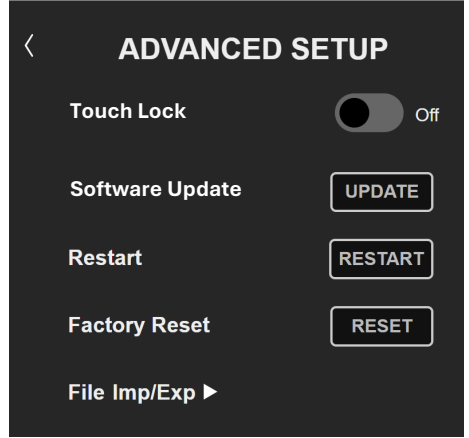

12.2 SOFTWARE UPDATE - MOBILE DEVICES

The Dynamic Trim Control System software can be updated using a mobile device (e.g smartphone, tablet or laptop). Visit zipwake.com to check for new software releases.

1. Download the upgrade file from zipwake.com to a mobile device. Connect the device to the integrator module via Wi-Fi or ethernet cable and start the Zipwake application.
2. Tap ☰ to open the System Menu.
3. Tap Advanced Setup.
4. Tap Software Update.
5. Tap UPDATE.
6. Tap Choose file and browse to the file downloaded to the mobile device.
7. Once the file has been uploaded to the integrator module, tap START to initiate the update.
8. Once the update process has finished, tap RESTART.

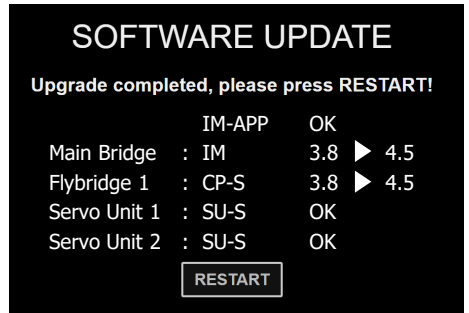
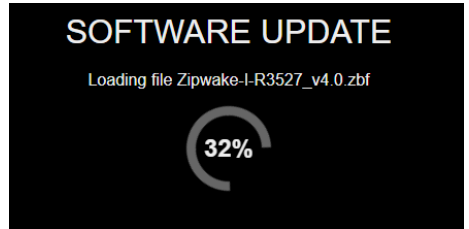

12.3 SOFTWARE UPDATE - OPTIONAL CONTROL PANEL

The Dynamic Trim Control System software can also be updated using a Zipwake control panel (optional). Visit zipwake.com to check for new software releases.

IMPORTANT The software upgrade file must be saved to the root of a USB memory stick with FAT32 formatting when upgrading the system.

1. Download a software upgrade file from zipwake.com.
2. Copy the software upgrade file to the root of the USB memory stick.
3. Remove the USB (A) connector cover on the back of the control panel and connect the USB memory stick to the DEVICE connector.
4. Restart the system and follow the instructions on the display.
5. Remember to remove the USB memory stick and put the connector cover back in place when done.



NOTE!

Your System Configuration (user settings) and Auto Pitch Control Curve will not be erased when you upgrade to another software version. You can also downgrade to a previous software release.

12.4 RESTART THE SYSTEM

1. Tap to open the System Menu.
2. Tap Advanced Setup.
3. Tap RESTART to restart the system

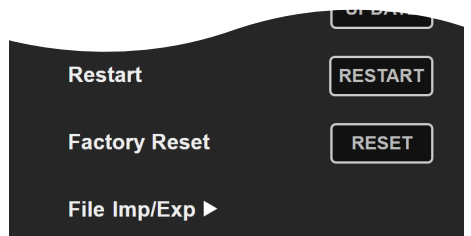

12.5 FACTORY RESET

To reset the settings and the Auto Pitch Control Curve to default, perform a Factory Reset.

IMPORTANT A Factory Reset resets all values and settings in the system. You can backup (chapter 12.6) and reinstall either the settings or the Auto Pitch Control Curve after a Factory Reset has been performed.

1. Tap to open the System Menu.
2. Tap Advanced Setup.
3. Tap RESET to conduct the Factory Reset.
4. Tap OK in the pop-up window to confirm.
5. The system will now reset all the settings and turn off.
6. Start the system and perform a new setup via the initial start (chapter 5).

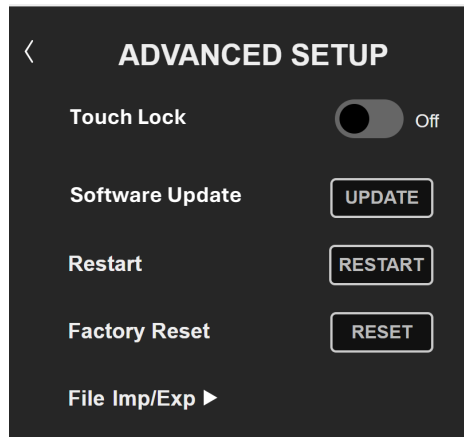

12.6 IMPORT/EXPORT DATA

Backup the Auto Pitch Control Curve and settings to a mobile device (e.g smartphone, tablet or laptop) for re-installation and/or to transfer settings between systems/boats.

1. Tap  to open the System Menu.
2. Tap Advanced Setup.
3. Tap File Imp/Exp.
4. Export or Import Pitch Curve or System configuration, respectively. Follow the steps.

NOTE!

We recommend that you do not use the MFD file system for imports or exports.

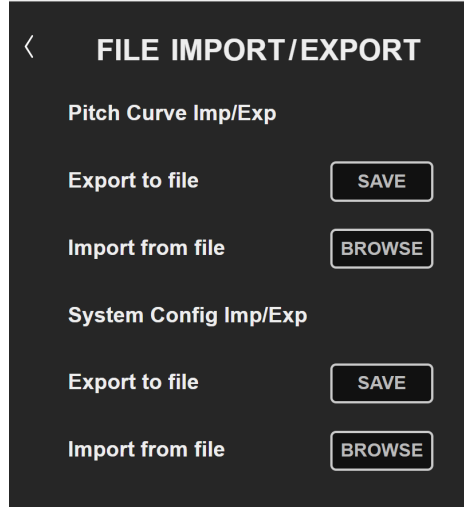

13 NMEA 2000

When connected to an NMEA 2000 network, the Zipwake system can receive GPS data from compatible devices, and transmit data to allow monitoring on e.g. MFDs or plotters.

Refer to the NMEA 2000 documentation at zipwake.com for more information (transmitted and received signals etc.).

NOTE!

If multiple Zipwake control units (control panel(s) and integrator module) are installed, only one of them should be connected to the NMEA 2000 network.

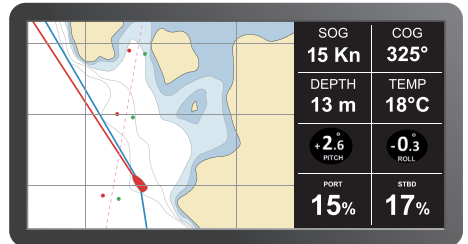

14 TROUBLESHOOTING

14.1 SYSTEM ERROR INFORMATION

A flashing error symbol (A) indicates system errors that need attention.
An interceptor error symbol (B) indicates an error with one or more interceptors.
A red GPS symbol (C) indicates that there is no GPS connection.
For a complete list of error descriptions and corrective actions see chapter 14.2.

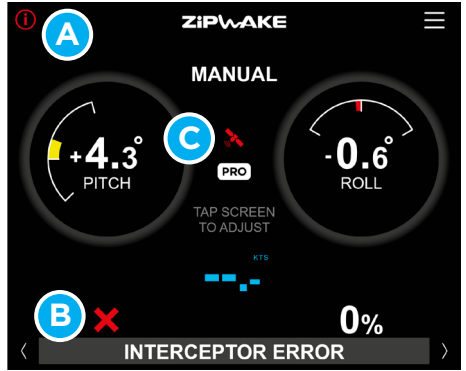

1. Tap  to open the System Menu.
2. Tap System Information.
3. Tap the unit that reports an error (marked in red).
4. Read the error message(C) and go to chapter 14.2 for corrective actions.

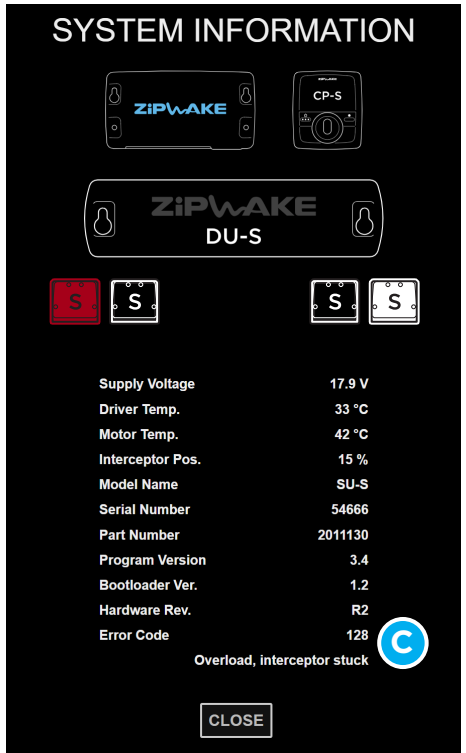

14.2 ERROR CORRECTIVE ACTIONS

Check the corrective actions below to resolve problems. Visit zipwake.com for the latest product information, software upgrades and error corrective actions. If the problem remains, contact your retailer for support and/or replacement units.

Control Panel Error Messages

Supply voltage too low

- Check battery supply voltage (>12V).
- Check the power cable connection to the battery.

Supply voltage too high

- Check the distribution unit(s) power cable.
- Check battery supply voltage (12-32V).

Button/wheel failure

- Check if any buttons or wheels are stuck.
- Use fresh water to spray and remove any dirt on the control panel front.

Acc/gyro error

- Turn off the system for 10 minutes, then restart.

Panel temperature too high

- Check if the panel is mounted close to any heat source.
- Try mounting the panel in another (cooler) location.

Program error

- Restart the system.
- Visit www.zipwake.com for upgrades resolving the issue.

Interceptor config changed

- Go to Interceptor Configuration menu page to check which interceptor(s) differ from what is saved to the system.
- Save the correct interceptor configuration if not already accurately saved to the system.
- Check the servo cable(s) for damage.
- Clean and reattach the connector(s) to the distribution unit(s)

Invalid Interceptor config

- Make sure interceptors are connected in pairs to the distribution unit(s), starting from connectors P1/S1. Refer to the Installation Guide for information about which connector(s) to connect a center-mounted interceptor.
- Check the servo cables for damage.
- Clean and reattach the connectors to the distribution unit(s).

Communication error

- Check the system cables for damage.
- Clean and reattach connectors to the distribution unit(s) and control panels.

No GPS signal

- Check GPS source and GPS status on the Select GPS Source menu page (normally set to Auto).
- If an external GPS or NMEA 2000 GPS is installed, check the cables for damage.
- Check that the NMEA 2000 GPS source is turned on.
- Clean and reattach the control panel connectors.

Interceptor/Servo Unit Error Messages

Supply voltage too low

- Check battery supply voltage (>12V).
- Check the power cable connection to the battery.
- Check the distribution unit(s) power cable.

Supply voltage too high

- Check battery supply voltage (12-32V).

Interceptor stroke too long

- Restart the system.
- Remove the interceptor front and check that the blades are moving correctly. Remove any growth, dirt or paint.
- Reinstall the front, run the interceptor and check that the blades are moving correctly.

Electronics failure

- Restart the system.
- Visit www.zipwake.com for upgrades resolving the issue.

Overload, interceptor stuck

- Check for excessive growth, dirt or paint on the interceptor and between the blades.
- Remove the interceptor front and check that the blades are moving correctly.
- Reinstall the front, run the interceptor and check that the blades are moving correctly.

Motor drive temperature high

- Turn off the system for 10 minutes, then restart.

Motor temperature high

- Turn off the system for 10 minutes, then restart.

Motor HALL sensor failure

- Turn off the system for 10 minutes, then restart.

Motor drive failure

- Turn off the system for 10 minutes, then restart.

Outside full stroke

- Restart the system (repeat if needed).
- Remove the interceptor front and check that the blades are moving correctly. Remove excessive growth, dirt or paint.
- Remove the servo unit from the back plate and make sure the nut on the screw shaft pulls in towards the center of the servo at start-up.

Start-up error

- Restart the system.
- Check battery supply voltage (12-32V).
- Check that the interceptor blades move correctly.

14.3 OTHER ERRORS

The system's automatic control functions remain off/turn off or turn on/off intermittently (can happen if there is a system error or if there is no GPS speed signal).

- Check error message flashing when turning on Auto / Auto Pitch Control.
- Check System Information Menu and error messages above to resolve the problem.

Auto / Auto Pitch Control turns on/off intermittently

(can happen if the GPS has a weak signal or poor satellite coverage).

- Check GPS status in the Select GPS Source Menu. Set GPS Source to Auto.
- Connect an NMEA 2000 GPS source if available. Refer to the Installation Guide.
- Install Zipwake external GPS. Refer to the Installation Guide.

The boat lists to port when the roll wheel is turned to starboard (clockwise) at speed

- Check how the interceptors are connected to the distribution unit(s).
- Refer to the Installation Guide for correct connection.

15 MAINTENANCE

 **WARNING** Watch out for sharp edges when close to the interceptors.

 **IMPORTANT** Always use the controls to move the interceptor blades. Never try to force the interceptor blades by hand.

15.1 LAUNCH

Paint the interceptors with anti-fouling paint before launching your boat. If possible use spray paint (recommended). When the paint is dry, remove excess paint between the interceptor blades. Before launching the boat, move the interceptor blades full strokes using the controls to ensure that they move freely and correctly. Refer to the Installation Guide for more information.

Verify acceptable servo torque levels by running an Interceptor Check (chapter 9.4).

15.2 HAUL-OUT

 **IMPORTANT** When your boat is hauled out of the water, do not place any supporting blocks pushing against the interceptors or blocking the interceptor blades.

After your boat has been hauled out of the water, use a pressure washer to remove any growth or dirt on the interceptors. Fully extend the interceptor blades using the controls and pressure wash them. Check the blades for damage. When washing is completed, retract the interceptor blades by turning off the system. Check that the cable covers are in place and not damaged. When the boat is hauled out after being in the water for an extended time, we recommend temporarily removing the interceptor fronts and pressure washing the inside of the interceptors thoroughly.

16 OPTIONAL MINI CONTROLLER

The Zipwake mini controller is the perfect complement for any Zipwake system with integrator module and MFDs. The small and intuitive mini controller provides easy manual control of running trim, heel or heading as well as system settings in the Zipwake integrator module application.

The Pitch and Roll wheels are speed progressive. A single “tick” on the Pitch or Roll wheel will move the interceptor blades one percent (1%). Turning a wheel faster equals more increments per “tick”. The number of increments when turning a wheel faster depends on the current speed of the boat. Low boat speed equals more increments and higher boat speed fewer increments, making manual pitch and roll control effective and safe.



Visit zipwake.com for additional information such as:

- Operator's Manuals and Installation Guides in different languages
- Product specifications, including a list of accessories and spare parts
- Application examples and interceptor mounting options
- Drawings and 3D models of system components
- Software upgrades for your Dynamic Trim Control System
- NMEA 2000 documentation

ZIPWAKE

TRIM CONTROL MADE EASY